

**OAKRIDGE PLANNING COMMISSION
STAFF REPORT
Hiland Ranch Partition
Staff Report Date: January 25, 2021
Planning Commission Public Hearing Date: January 26, 2021**

PROPERTY OWNER: Mr. Steven Ness of Hiland Ranch Properties
2880 Arrowhead Street
Eugene, OR 97404

SURVEYOR: Mr. Donald Nickell
3325 Craig Loop
Cottage Grove, OR 97424

REPRESENTATIVE: Mr. Aaron Noteboom of Noteboom Law, LLC
375 West 4th Ave, Ste 204
Eugene, OR 97401

SUBJECT PROPERTY: No Address Assigned

Assessors Map 21-35-16-00, Tax Lot 1300

ZONING: R-1 Low Density Residential

REQUEST: Partition Lot 36 of Elk Meadows-Phase 2 into three separate parcels. Parcel 1 will be approximately 3.6 acres, Parcel 2 will be approximately 2 acres and the remainder, Parcel 3, will be approximately 33.6 acres. Homesite development is expected on Parcels 1 and 2.

BACKGROUND:

Mr. Ness is requesting City approval of a tentative plan to partition tax lot 21-35-16-00-1300 into two single family residential lots, with a third parcel being a remainder. The applicant first submitted their application for partition to the City of Oakridge on September 11, 2019. It does not appear the application was processed after it was initially received. Staff at Lane Council of Governments (LCOG) were unable to discern the date the application was deemed incomplete or complete. As such, the City of Oakridge forwarded the application was forwarded onto the LCOG for processing and to bring the application in front a public hearing for a decision. Staff at LCOG received the City's application on July 10, 2020, at such time staff at LCOG reviewed the application for completeness and determined the application to be "incomplete" and issued a letter of incompleteness on July 13, 2020. The applicant submitted the requested items

contained in the incompleteness letter on November 12, 2020 and the application was deemed complete on November 25, 2020.

NOTICE: Agency referral notice of the proposal was sent to Public Works and Engineering was sent on November 12, 2020. The City Engineer issued comments on November 20, 2020 and a second set of comments on December 9, 2020, which clarified the initial comments. Notice to surrounding properties, pursuant to Oakridge Development Code was sent by LCOG on December 28, 2020. The City Engineer's comments are included in this staff report as **Attachment C** and the notice materials as **Attachment D**.

DESCRIPTION

The subject property consists of approximately 39.28 acres of land that slopes gently to the northeast. There are no existing buildings on or within 25-feet of the property lines for Parcel 1 or Parcel 2. There are only a handful of trees on the property of chest height with an approximate diameter of six inches. The only developed feature on the subject property is the all-weather gravel access road forming Bugle Loop.

UTILITIES

The applicant is proposing to take access onto Parcel 1 and Parcel 2 from the terminus of Bugle Loop. Existing tie into water, power and sewer are located at the same location as the Parcels would take access from. The applicant will tie into these existing utilities and extend, as necessary, to the single homesites.

FLOODPLAIN DESIGNATION

According to RLID property details for the subject property, the property has a FEMA flood designation of "X", which is determined to be outside of the 500-year flood zone. The property's detailed report is included in this staff report as **Attachment F**.

APPLICABLE APPROVAL CRITERIA - *In Bold Italics*

Ordinance 874: ARTICLE 4 - LOW DENSITY RESIDENTIAL DISTRICT (R-1) SECTION 4.02 USES AND STRUCTURES

(1) Permitted uses and structures:

(f) Manufactured homes; (h) Residential homes; (i) Single-dwelling unit;

(2) Permitted accessory uses and structures

(g) Garages, carports, or any parking space with direct, access from the street shall be set back at least 20 feet from a property line abutting a street.

FINDING: While the application does not authorize any construction of dwellings, it is the intention of the applicant to eventually place single-family dwellings on Parcel 1 and Parcel 2. As seen in Section 4.02 USES and STRUCTURES, a single-family home along with the permitted accessory uses are outright permitted uses in the R-1 zone. Criterion met.

SECTION 4.03 LOTS

Except as stated in Section 4.02, lots shall meet the following minimum requirements:

(1) Lot Area. The minimum lot area shall be 5,000 square feet.

FINDING: As seen in the applicant's submission materials (**Attachment A**), proposed Parcels 1, 2 and 3 are all above the minimum lot size of 5,000 square feet for the R-1 zone.

(3) Lot Dimensions. Except for flag lots and townhouse developments, the minimum lot width at the right-of-way shall be 30 feet, except corner lots that shall be a minimum of 50 feet wide. The maximum lot depth shall be no greater than three (3) times the lot width except as may be necessary to protect sensitive areas or address topographic limitations.

FINDING: The above code provision requires lots to abut rights-of-ways for 30- feet. As seen on **Attachment A**, Parcel 1 and Parcel 2 will share a common 50-foot access easement, with each Parcel comprising of 25-feet of that 50-foot access easement, which will abut the terminus of Bugle Loop. In the applicant's January 8, 2021 submittal (**Attachment B**), the applicant sets forth two arguments as to how the proposal meets the above code standards. In the first argument, the applicant contends the provision does not apply because "lots" are created via a subdivision process and the proposal is to create "parcels." Staff does not agree with the applicant in this instance, because the code is using "lot" as a generic term in this sense and if the applicant's argument were true, the code would also set forth basic standards for "parcels," but the code does not make such a distinction.

In the applicant's second argument, it is contended that the proposal does meet the provision because the term "right of way" is defined as "an area or strip of land, either public or private, on which an irrevocable right-of-passage has been recorded for the use of vehicles or pedestrians or both." In this case, each of the new parcels will exceed the 30-foot requirement by virtue of either the proposed access easement or abutting the terminus of existing streets. This argument is one the City finds acceptable. Additionally, what's important to note is that both Parcel 1 and Parcel 2 will have a legal right and access to the full 50-foot right-of-way via the access easement. In Oakridge, access easements are generally called "Joint Access." The remainder of Parcel 3 will have 50-feet of access where it terminates with Bugle Loop, Six Point Drive, Hiland Ranch Drive, Spike Drive, Cow Crossing Drive and Shed Lane. Each of those access points are in road rights-of-way that are in excess of 30-feet. Criterion met.

(4) Lot Coverage. The maximum coverage of the lot by all structures shall be 35 percent, except duplexes and tri-plexes which shall not cover more than 45 percent of the lot area, and townhouses, which shall not cover more than 55 percent of the lot area. The maximum coverage for all structures, driveways, parking areas, patios, and other impervious surfaces shall be 65 percent.

FINDING: Lot coverage cannot be verified at this time as the partition will only create new legal lots and not authorize any development on structures. Lot coverage will be verified at the time of building permit submittal. Criterion not applicable.

SECTION 4.04 YARDS

(1) Front.

(a) Provided it will not result in an encroachment into a public utility easement or preclude future development of rights-of-way to the standard cross-section described in the adopted Transportation System Plan, each lot shall maintain a minimum front yard as follows:

(i) Eight (8) feet in front of any unenclosed porch;

(ii) Ten (10) feet in front of other structures;

(iii) Twenty (20) feet in front of any garage or carport.

(b) Front yards shall not be used for accessory buildings, clotheslines, incinerators, permanent storage of recreational and other vehicles, trailers, boats, or of any other materials. A front yard shall not be used to meet the permanently reserved parking requirements for automobiles or other vehicles.

(2) Side. Each lot shall maintain a side yard on each side of the lot of at least five feet, except corner lots that shall have a side yard abutting the street of at least 10 feet.

(3) Rear. Each lot shall maintain a rear yard of at least 10 feet from the rear property line.

FINDING: Setbacks cannot be verified at this time as the proposed partition will not authorize the development of any structures. The applicant will be required to obtain the appropriate building permits for construction of homes. Setbacks to be verified at time of building permit submittal. Criterion not applicable. The proposed Parcels have ample space to realistically meet setbacks.

SECTION 4.05 HEIGHT LIMITS

(1) Residential structures. The maximum height of any residential structure shall be 2-1/2 stories or 28 feet, whichever is less.

(2) Accessory structures. The maximum height of any accessory structure shall be one story or 15 feet, whichever is less.

(3) All other structures shall not exceed three stories or 35 feet in height, whichever is less.

FINDING: No existing height information has been provided at this time; no new structures proposed. Maximum height will be verified at time of building permit submittal.

SECTION 4.06 FENCES, HEDGES, WALLS AND OTHER STRUCTURES

Sight-obscuring fences, hedges, walls, and other structures shall not exceed 2-1/2 feet in height in front yards and six feet in height in all other cases. Fences and walls that do not obscure sight shall be no more than six feet in height.

FINDING: No fences are proposed as part of the partition process. If fences are proposed as part of homesite development, fence standards will be reviewed at the time of building permit submittal. Criterion not applicable.

CHAPTER 151: SUBDIVISIONS

151.063 INFORMATION ON TENTATIVE PLAN MAP. The following information shall be contained on or with the tentative plan map:

(A) A legal description of record of the proposed site;

FINDING: Staff were able to find and include a copy of the legal description of the site using the Regional Land Information Database. The legal description is attached to this staff report as **Attachment F**. Criterion met.

(B) Lot dimensions and parcel layout showing the size and relationship of each parcel to existing or proposed streets, pedestrian facilities and bikeways and utility easements;

FINDING: The applicant provided sketches of the existing and proposed Parcel layout showing the size and relationship of each parcel to existing streets, pedestrian facilities and bikeways and utility easements, where applicable. The maps are included in this staff report as **Attachment A**. Criterion met.

(C) For land next to and within the tract to be partitioned, the locations, names and widths of streets; location, use, width and names if appropriate other pedestrian facilities and bikeways; location, width and purpose of other easements; location and size of sewer and water lines, drainage ways and other serving utilities;

FINDING: The applicant provided sketches of the existing and proposed Parcel layout showing the size and relationship of each parcel to existing streets, pedestrian facilities and bikeways , location of public utilities and utility easements, where applicable. The maps are included in this staff report as **Attachment A**. The proposed parcels have existing utilities in place nearby that can be extended the property lines to serve the eventual homesites. Criterion met.

(D) Location of buildings on the tract and within 25 feet of the property line of the tract, slope of land, trees with a trunk diameter at chest height of six inches or greater and other features of the land important to its development;

FINDING: The applicant has indicated in their written narrative that there are no buildings on the tract and within 25 feet of the property line of the tract. The subject property currently consists of a handful of trees of about chest height and the only developed feature on the property is the all-weather gravel access road forming Bugle Loop. Criterion met.

(E) The number and type of units proposed where known and appropriate;

FINDING: No improvements are being proposed as part of the proposal. Criterion met.

(F) Proposed improvements such as pavements, curbs and gutters, sanitary and storm sewers, sidewalks, bikeways, grading and filling and other major improvements to develop the parcels;

FINDING: The subject property contains adequate access and utilities to accommodate the two proposed Parcels. Proposed Parcels 1 and 2 will connect to the terminus of the existing Bugle Loop road and connect to existing power, water and sewer. The City Engineer has issued comment on the proposal and stated the City will not require any new public infrastructure for partitioning the property to create Parcels 1 and 2. Existing infrastructure is in place to serve homesite development on Parcels 1 and 2. However, additional development of Parcels 1, 2 and 3, beyond a single homesite development on Parcels 1 or 2, will require the construction of sidewalks, roads, and utility corridors, as necessary, in the locations shown on the approved partition maps as platted in the Elk Meadows Subdivision. The City Engineer recommends the following conditions of approval, as seen in **Attachment C:**

Condition of Approval #1: Additional development of Parcels 1, 2 and 3, beyond that discussed as part of the applicant's present partition proposal, will require the construction of sidewalk, road and utility corridors, as necessary, in the locations shown on the approved Elk Meadows Subdivision Plat.

Condition of Approval #2: The development of a single residence on each of the Parcels 1 and 2, as proposed, does not require additional construction of utilities or roadway, other than that required to serve the residences and the installation of the water main as provided in COA #3. All such access and utilities shall be located within dedicated easements.

(G) The location, width, name, if appropriate, and approximate grade and curve radii of adjacent streets, pedestrian facilities and bikeways; (The relationship of streets, pedestrian facilities and bikeways to any existing or proposed streets, pedestrian facilities and bikeways, and as shown in the city's transportation system plan.)

FINDING: The applicant has shown the roadway cuts of the existing roadways in their application submittal. The proposed Parcels are part of an approved subdivision that has been platted, so rights-of-way have already been dedicated. The proposed parcels will take their legal access from Bugle Loop and can tie into existing water, sewer and electric that is located nearby in the rights-of-way. The City will not require any new infrastructure improvements as part of this partition proposal but will require improvements for developments outside of what is presently proposed. Criterion met.

(H) In addition, when all or part of the area encompassed in a partition application has not been previously included in a recorded plat (subdivision) of lots averaging a maximum of ¼ acre each, the following information is also required:

FINDING: The area encompassing the proposed partition has been previously included and recorded in a Final Subdivision Plat titled Elk Meadows Subdivision. Criterion not applicable.

(1) Where it is apparent that the subject parcel can be further partitioned, the divider must show that the land partition will not preclude the efficient division of land in the future. (Ord. 805, § 5.04, passed 8-17-95; Am. Ord. 841, passed 12-7-00)

FINDING: The applicant has included a conceptual shadow plat in their application materials as to how the remainder of the property can be further subdivided in the future. Each of the future possible land divisions have the ability to connect to public right-of-way and have frontage upon the right-of-way. Criterion met.

151.066 FINAL APPROVAL AND RECORDING.

(A) The city may grant final approval for the partition after:

(1) All ordinance requirements and conditions of approval specified in the notification to applicant have been met; and

FINDING: Staff find the applicant has submitted a tentative partition plat that can be given tentative approval, subject to the recommended conditions of approval as recommended by the City Engineer. The applicant, following tentative approval, will have to prepare a final partition plat for final plat approval and recording with Lane County. A tentatively approved partition plat does not authorize any construction activities. The appropriate building permits will have to be applied for and obtained.

(2) A current title report issued by a title insurance company in the name of the owner of the land, showing all parties whose consent is necessary and their interest in the premises. The following relevant documents have been approved by the city: deeds; dedications; easements and agreements. The applicant has submitted a surveyed partition map meeting the following requirements:

(a) It shall be prepared by a state registered professional land surveyor in accordance with O.R.S. Chapter 92 and 209. The map shall conform to the partition map standards established by the County Surveyor. The surveyor shall submit one copy of the map to the city and the original and one copy, with the appropriate recording fee, to the County Surveyor; and

(b) A state registered professional land surveyor shall survey and monument the parcels. All monuments on the exterior boundary and all parcel corner monuments of partitions shall be placed before the partition is offered for recording. The surveyor shall file a map of survey and submit the appropriate filing fee to the County Surveyor.

FINDING: The applicant will be required to obtain and submit the required documents and approvals as described above in Section 2 (a) and (b), for final recording purposes. The applicant is reminded to submit one copy of the final survey to the City of Oakridge for the City's recording keeping purposes.

(B) After the city has granted approval for the partition, all deeds, dedications, easements and agreements shall be recorded in the county's deed records by the city at the divider's expense.

FINDING: The final partition plat to be prepared by a licensed and registered surveyor will be required to contain all deed, dedications, easements and agreements. This requirement is standards for platting and recording procedures in the state of Oregon.

(C) The land divider is responsible for all recording costs. If any recording is done on behalf of the land divider by the city, those charges shall be estimated by the city prior to the recording. Before any documents are submitted for recording, the estimated fee shall be deposited with the city. If the actual recording fees are less, the balance shall be refunded to the land divider. If they are more, the land divider shall pay the balance.

FINDING: The applicant will be responsible for all recording costs. The City is not aware of a proposal for the City to handle the recording of the final partition plat. If the City will be the authority recoding the final partition plat on behalf of the applicant, then the applicant will be required to pay the estimated fees associated with the recording of the final partition plat. Nonetheless, it's the applicant's responsibility to pay for the recording costs and staff expect the applicant and their surveyor will be the ones to take the final partition plat to Lane County to be recorded.

(D) Once recorded copies of the partition and all documents are returned to the city and all fees have been paid, a copy shall be mailed to the land divider.

FINDING: The applicant is reminded that a final copy of the final partition plat shall be furnished to the City for the City's recording keeping purposes. Criterion met.

(E) One signed copy of the surveyed partition map shall be placed in the city land division file, including a notation citing the County Surveyor's date of recording, the recorded survey map and file number, and the County Office of Deeds and Records recording numbers of all documents recorded with the county. (Ord. 805, § 5.07, passed 8-17-95; Am. Ord. 841, passed 12-7-00)

FINDING: No specific finding required here that has not already been addressed in the above findings for Chapter 151.066. The recording of the final partition plat is standard and will be conducted in accordance with state and county recording laws and procedures.

Chapter 151.103 IMPROVEMENTS IN PARTITIONS

The same improvements may be installed to serve each building site of a partition as is required of a subdivision. However, if the Planning Commission finds that the nature of development near the partition makes installation of some improvements unreasonable, the Planning Commission may except those improvements. Instead of excepting an improvement, the Planning Commission may recommend to the City Council that the improvement be installed in the area under facility extension policies of the city. (Ord. 805, § 7.04, passed 8-17-95; Am. Ord. 841, passed 12-7-00)

FINDING: The applicant indicates, and the City Engineer has confirmed that proposed Parcels 1 and 2 have the ability to connect to city service lines that are existing in the nearby right-of-way. The applicant will make use of the existing nearby infrastructure and facilities while allowing a modest number of new housing stock. Should either of these two new Parcels be further divided, the applicant proposes a condition of approval that appropriate infrastructure would be required at that time. As such, the applicant, the Public Works Director and the City Engineer met recently to discuss a condition of approval that allows the applicant to continue to partition as they propose while at the same time ensuring the city's infrastructure is extended appropriately when new homesites develop. The intent of the City Engineer's recommended condition is that the sectional extension of the existing municipal water distribution system in Elk Meadows, as proposed in the originally platted subdivision, shall occur from current and future partitioning. This requirement, and the City's states acceptance of the proposed partitioning does not exempt parcel owners from the individual infrastructure construction requirements described in the condition of approval below, when parcel subdivision for "further residential development" occurs.

As a result of these efforts, the City recommends Planning Commission consider a **Condition of Approval #3, as seen in Attachments B and C:**

Condition of Approval #3: Additional land division of Parcel 1 or Parcel 2 for further residential development will require the construction of sidewalk, road and utility corridors, as necessary, in the locations shown on the approved partition map(s) to service those additional parcels or lots. The remainder of Parcel 3 may be further partitioned, in one or more applications, with each partition application creating two new residential parcels and one remainder parcel. With respect to each such partition application, provided that the new residential parcels abut the terminus of an existing paved street allowing connection to existing sewer, water and power, the new residential parcels may take access to and connect with the existing street and utilities and no additional infrastructure shall be required to be constructed in connection with the development of those residential parcels. Additional land division of either of the residential parcels for further residential development will require the construction of sidewalk, road and utility corridors, as necessary, in the locations shown on the approved partition map(s) to service those additional parcels or lots. This process may be repeated for each of the nine (9) street terminuses abutting the currently vacant lot 36. All access and utilities shall be located within the dedicated access and utility easement except for where such access and utilities divert from said easement to service the individual residences.

Any and all parcels created, including the currently proposed Parcel 1 and Parcel 2, which abut utility right of way where water main is shown on the original platted plans (Elk Meadows), shall have that section of water main bordering the Parcel constructed as a condition of sale of said parcel. The water mains shall be a minimum six-inch diameter, of C900 PVC construction, with fire hydrants and valving installed every 500-feet and will conform to the City Public Works Standards and all construction requirements shown in the original platted plans of Elk Meadows. Nothing in this condition requires that any residential parcel or remaining parcel be further partitioned or subdivided or prohibits the subdivision of any residential or remaining parcel.

STAFF RECOMMENDATION

Staff recommends Planning Commission **APPROVE** the proposed partition, subject to the conclusions, findings and conditions as stated in this staff report.

CONDITIONS OF APPROVAL

Condition of Approval #1: Additional development of Parcels 1, 2 and 3, beyond that discussed as part of the applicant's present partition proposal, will require the construction of sidewalk, road and utility corridors, as necessary, in the locations shown on the approved Elk Meadows Subdivision Plat.

Condition of Approval #2: The development of a single residence on each of the Parcels 1 and 2, as proposed, does not require additional construction of utilities or roadway, other than that required to serve the residences and the installation of the water main as provided in COA #3. All such access and utilities shall be located within dedicated easements.

Condition of Approval #3: Additional land division of Parcel 1 or Parcel 2 for further residential development will require the construction of sidewalk, road and utility corridors, as necessary, in the locations shown on the approved partition map(s) to service those additional parcels or lots. The remainder of Parcel 3 may be further partitioned, in one or more applications, with each partition application creating two new residential parcels and one remainder parcel. With respect to each such partition application, provided that the new residential parcels abut the terminus of an existing paved street allowing connection to existing sewer, water and power, the new residential parcels may take access to and connect with the existing street and utilities and no additional infrastructure shall be required to be constructed in connection with the development of those residential parcels. Additional land division of either of the residential parcels for further residential development will require the construction of sidewalk, road and utility corridors, as necessary, in the locations shown on the approved partition map(s) to service those additional parcels or lots. This process may be repeated for each of the nine (9) street terminuses abutting the currently vacant lot 36. All access and utilities shall be located within the dedicated access and utility easement except for where such access and utilities divert from said easement to service the individual residences.

Any and all parcels created, including the currently proposed Parcel 1 and Parcel 2, which

abut utility right of way where water main is shown on the original platted plans (Elk Meadows), shall have that section of water main bordering the Parcel constructed as a condition of sale of said parcel. The water mains shall be a minimum six-inch diameter, of C900 PVC construction, with fire hydrants and valving installed every 500-feet and will conform to the City Public Works Standards and all construction requirements shown in the original platted plans of Elk Meadows. Nothing in this condition requires that any residential parcel or remaining parcel be further partitioned or subdivided or prohibits the subdivision of any residential or remaining parcel.

Condition of Approval #4: Final partition plat shall be recorded in accordance with ORS 92 and local, county and state recording requirements. The Final Partition Plat shall show the locations of all previously established utility corridors in addition to any and all new partitioning. Applicant shall furnish a final copy of the approved and recorded partition plat to the City Administrator for the City's recording keeping purposes.

Condition of Approval #5: Approval of a partition does not authorize any construction or building of improvements. The applicant shall be required to obtain the appropriate building permits before any construction activities commence.

Attachments

Attachment A – Application

Attachment B – Applicant's supplemental materials

Attachment C – City Engineer's comments

Attachment D – Notice materials

Attachment E – Findings of fact to be signed by Planning Commission Chair

Attachment F – Property information details

ATTACHMENT A

RECEIVED

Planning Commission
City of Oakridge

9-11-19

JMS

Type of Permit: Minor Partition

Property Description (metes and bounds legal description may be attached): _____

Lot 36 , Elk Meadows- Phase 2, except all of that portion of Phase 3 of

Elk Meadows.

Assessor's map and tax lot number: 21-35-16-00 TL 1300

Property Address: Vacant parcel of land

Existing Zone District: R-1 Low Density Residential

Property presently used for: Single family dwelling

Applicant intends to use property for: Partition the parcel into 3 parcels

Registered Engineer or Surveyor preparing plat:

Name: Donald Nickell % Nickell Land Surveying

Address: 33225 Craig Loop, Cottage Grove, Ore. 97424

Phone: 541-968-2905

Email: nickell2u@msn.com

notice

I (print) Steve Ness PRES. HILAND RANCH PROPERTIES, INC., hereby certify that the foregoing statements, answers and information attached and bearing my signature are true and accurate to the best of my knowledge and belief, and that I am the (check one) owner of record, _____ contract purchaser, or _____ of the real property involved in this application.

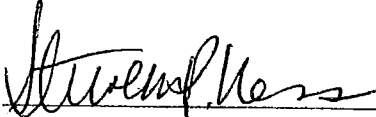
Signature:  Date: 3-29-19

Mailing Address: 2880 Arrowhead Street Eugene, Oregon 97404

Phone: 541-461-3304 Email steveness1@comcast.net

Office Use Only
Date Filed: 9-11-19

Fee Paid: 300.00

Public Hearing Date: 10-15-19

NARRATIVE FOR PRELIMINARY PARTITION

List of zoning requirements

Section 4.02 Uses and Structures

The City code minimum parcel size is 5000 square feet for a single family dwelling and 7000 square feet for a duplex parcel. The proposed parcel size is 3.6 acres for Parcel 1, 2.0 acres for Parcel 2 and 33.6 acres for Parcel 3. The owner is requesting that all 3 parcels will have a single family dwelling. The owner may at a later time request accessory building for each parcel. The owner may at a later time request to do either a subdivision or partition. And at that time will be working with the City of Oakridge to get the necessary permits, if needed.

Section 4.03 Lots

The proposed parcel size is 3.6 acres for Parcel 1, 2.0 acres for Parcel 2, and 33.6 acres for Parcel 3, which exceeds the City's code of 5,000 square feet. Parcels 1 and 2 have a road frontage of 25 feet (wide) with a 50 foot wide private road easement which exceeds the City's code requirement of 30 feet wide. Proposed Parcel 3 has 7 road frontage of either 50 feet or 60 feet wide which meets the minimum code requirement.

Section 4.04 Yards

All the requirements of this section will be met for the yards of each proposed dwelling site.

Section 4.05 Height Limits

All the requirements of this section will be met for the height limits at the time the landowner applies for a building permit for each dwelling.

Section 4.06 Fences, Hedges, Walls and other structures

The landowner will work with the City staff prior to any placement of a fence, hedge, walls or other structures.

Section 4.07 Off-Street Parking

Prior to applying for a building permit the landowner will show on the required building plot plan how the placement of off street parking will meet the City's code requirements.

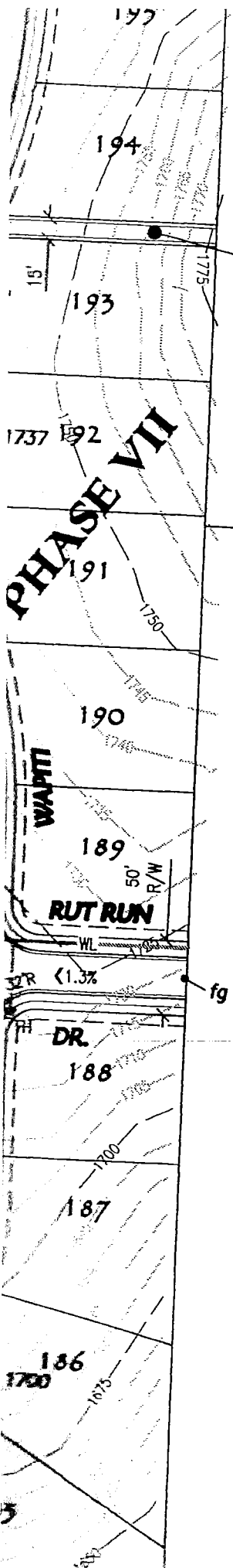

TRACT D
SIDEWALK ACCESS

- PROPOSED FIRE HYDRANT
- SD PROPOSED STORM DRAIN
- PROPOSED CURB INLET
- SS PROPOSED SANITARY SEWER
- SS/FM PROPOSED SANITARY SEWER FORCE MAIN
- PROPOSED MANHOLE (SEWER OR STORM DI)

fg 1737

PROPOSED STREET & FINISHED GRADE,
ALL GRADE BREAKS SHALL HAVE A VERTICAL
CURVE TRANSITION, LENGTH TO BE
DETERMINED DURING FINAL DESIGN

5.0%

PROPOSED FINISHED GRADE OF STREET +
DIRECTION OF FLOW

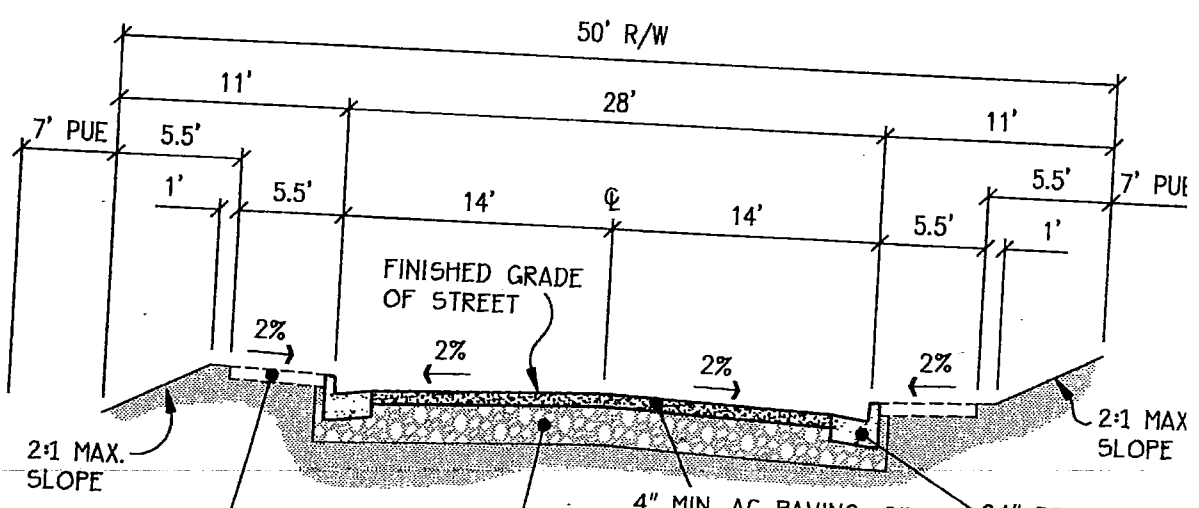

5' WIDE PCC SIDEWALK
(TO BE BUILT W/ HOME
DEVELOPMENT), TYP.

12" MIN. BASE ROCK, OR
PER SOILS ENGINEER
RECOMMENDATIONS

4" MIN. AC PAVING, OR
PER SOILS ENGINEER
RECOMMENDATIONS

24" PCC CURB
+ GUTTER, TYP.

28' TYPICAL STREET SECTION

- COW CROSSING
- PORTION OF WAPITI LOOP
- SHED LANE
- BUGLE CROSS
- RUT RUN DRIVE
- VELVET LANE

EXHIBIT "B"

60' R/W

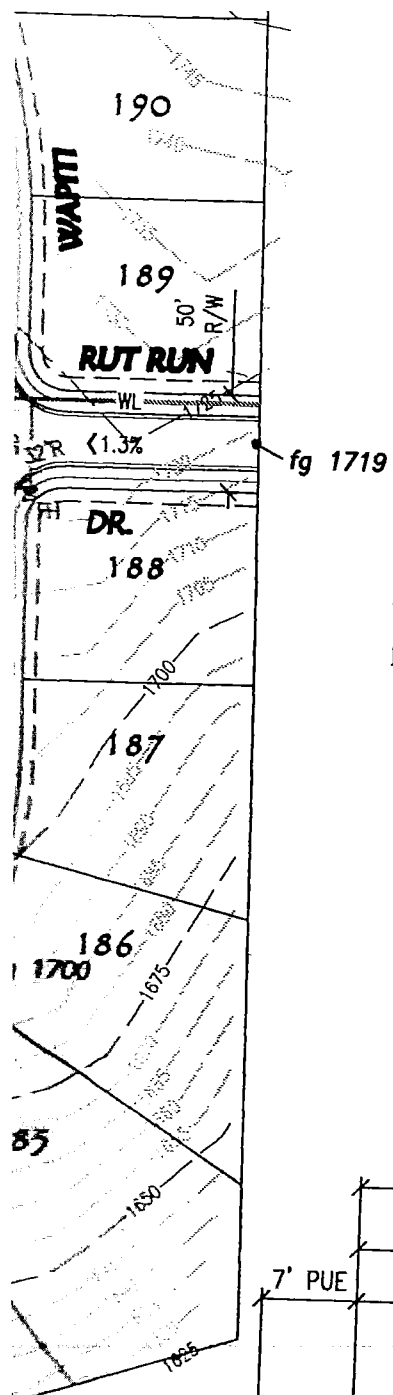

fg 1719

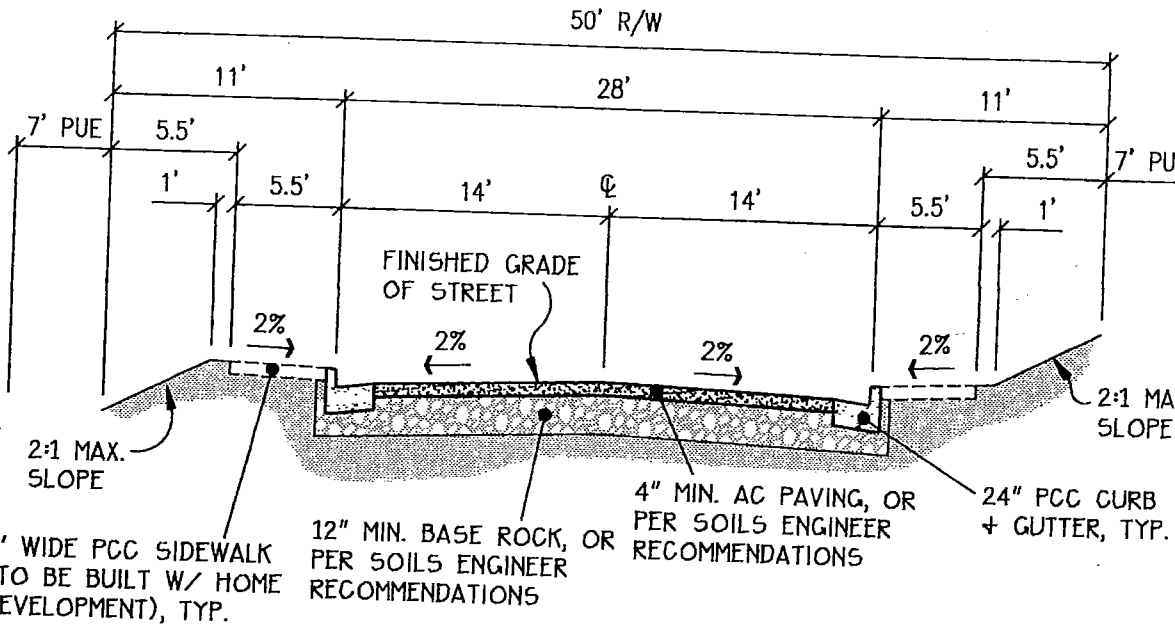

28' TYPICAL STREET SECTION

COW CROSSING
 PORTION OF WAPITI LOOP
 SHED LANE
 BUGLE CROSS
 RUT RUN DRIVE
 VELVET LANE

TAX LOT 103
 MAP 21-35-15

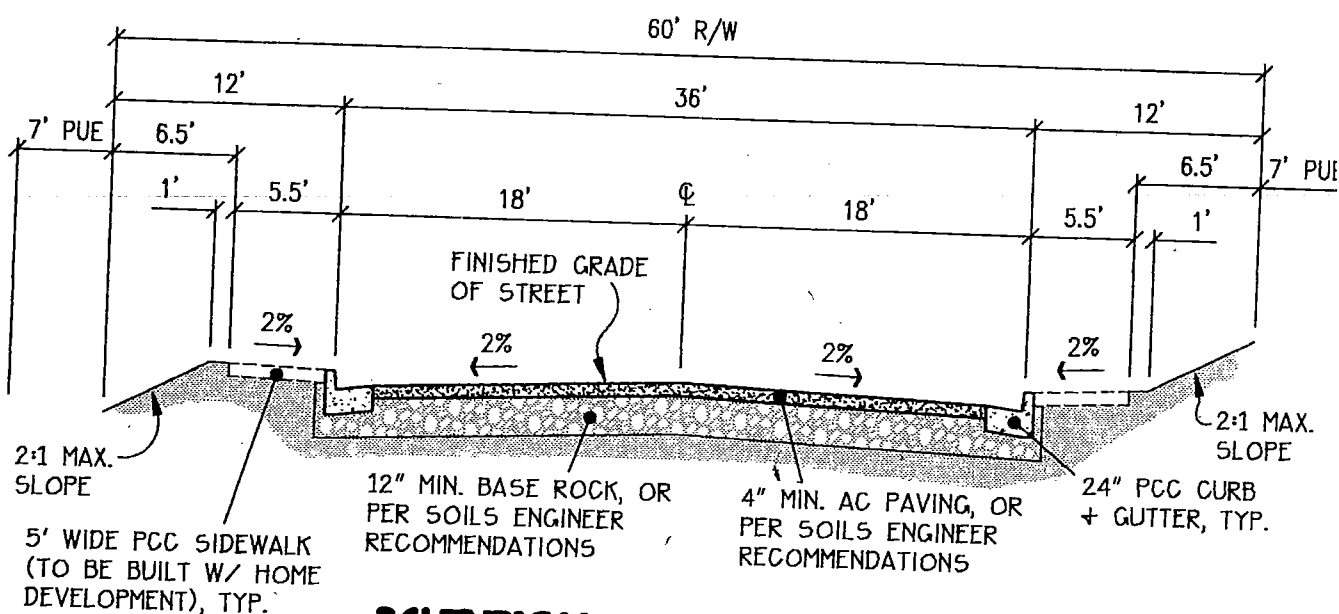

36' TYPICAL STREET SECTION

HIGHLAND RANCH DR.
 PORTION OF WAPITI LOOP
 PORTION OF ANTLER WAY

NOT TO SCALE

EXHIBIT C

Elk Meadows 21-35-16-00 TL 1300

Excerpts from Ordinance 805;

ARTICLE 2 -APPLICATION AND VARIANCE PROCEDURES

SECTION 2.01 PRELIMINARY REVIEW

Before submitting an application and a tentative plan for a subdivision or partition, a land divider or the divider's agent shall submit a letter and a sketch drawing for the layout of property to be divided to the City Planner for preliminary review. The purpose of the review shall be to inform the land divider of conditions and policies of public or private agencies that may be relevant to the preparation of the application and tentative plan. After the review, the City Planner may recommend filing an application and preparation of a tentative plan for review and action. The City Planner may also suggest a land division conference with affected agencies to help the land divider in preparing the tentative plan.

SECTION 2.02 LAND DIVISION CONFERENCE

Within 14 days after the preliminary review, the City Planner may schedule a land division conference with the land divider and representatives of the City and other affected public and private agencies. The purpose of the conference is to clarify the conditions and requirements necessary to prepare the application and tentative plan. The land divider may request additional meetings with affected agencies as necessary to clarify policies that may affect the proposed land division.

SECTION 2.03 SUBMISSION PROCEDURE

After preliminary review and the land division conference, where applicable, the land divider shall prepare an application and a tentative plan. Other supplementary data required to show the general program and objectives of the proposed land division, such as information about slopes, water and sewer delivery systems and so on, shall accompany the application. The application shall be submitted on a City form for that purpose to the City Planner. The submission and informational requirements and review procedures shall be as specified for each land division classification contained in this ordinance.

SECTION 2.04 SERVICE CHARGE

A service charge established by the City shall be paid to the City at the time the application is submitted. A schedule of fees shall be available at City Hall for this purpose. The charge shall be besides other fees established by state or county regulations. The service charge is nonrefundable unless the applicant withdraws the application before the City has incurred any expense in processing the request.

SECTION 2.05 VARIANCES

1. Variances Authorized. Variances to the requirements of this ordinance may be authorized by the Planning Commission, as provided by ordinance.
2. Application. Petition for a variance shall be made on a City form and submitted to the City Planner at the time the land division application and tentative plan are submitted. The variance petition shall cite the ordinance provisions from which a variance is requested. It shall also fully state the basis and facts relied upon, and other data pertinent to the requested variance.
3. Review and Action Procedure
 - a. City staff shall review the variance petition with all affected public and private agencies and submit a finding report to the Planning Commission

- b. The Planning Commission shall consider the variance petition at the same meeting at which it considers the land division application and tentative plan. A variance may be granted provided all the following circumstances exist:
- i. The need for the variance does not result from a previous deliberate action of an owner of the property, either under this ordinance or under ordinance and policy then current.
 - ii. There are unique circumstances or conditions affecting the property
 - iii. The variance is necessary for the proper design and/or function of the land division.
 - iv. The granting of a variance will be in the interest to the public welfare and will not be harmful to other property in the area in which the property is situated.
 - v. The granting of the variance complies with Comprehensive Plan and other relevant ordinances of the City.
 - vi. The variance is necessary for the preservation and enjoyment of a substantial property right because of an extraordinary hardship that would result from strict compliance with the regulations of this ordinance.
 - vii. The variance is the minimum necessary in order to provide the desired relief.
 - viii. If the variance is from a utility standard, flood hazard or slope requirement, the variance has the written approval of the City Engineer.
 - ix. And, if applicable, the variance is necessary to conform to an approved planned unit development approach which uses new planning and development techniques that do not necessarily conform to the more conventional standards of land division, design or improvements prescribed by this ordinance.
- c. The Planning Commission may approve, conditionally approve or deny all or any part of a variance petition. If the petition is approved, a written record of the findings and action of the Planning Commission shall be attached and noted on two copies of the tentative plan as part of the conditions for approval of the proposed land division. If the petition is denied, the land divider shall be informed in writing within 5 working days of the hearing.

Article 5, Land Partitions exerts from Ord 805

5.01 Two or three parcels within a calendar year.

5.02 10 copies of tentative plan map for partition with an application, and supplemental data. Shall comply with Article 2 & ORS Chapter 92.

5.03 Shall be clearly legible on 18x24 with verbal scale 1" =30' or 1" =50' or 1"= 100" shall show details and related data.

5.04 The following information shall be on or with tentative map;

1. A legal description of record of the proposed site.
2. Lot dimensions and parcel layout showing the size and relationship of each parcel to existing or proposed streets and utility easements.
3. For land next to and within the tract to be partitioned, the locations, names and widths of streets; location, width and purpose of other easements; location and size of sewer and water lines, drainage ways, and other serving utilities. *need info*
4. Location of buildings on the tract and within 25 feet of the property line of the tract, slope of land, trees with a trunk diameter at chest height of six inches or greater and other features of the land important to its development. *Due to size of parcel 3, cost prohibited*

1, 2, 5 →

Check code for time frames

need info

5. The number and type of units proposed where known and appropriate
6. Proposed improvements such as pavements, curbs and gutters, sanitary and storm sewers, sidewalks, grading and filling, and other major improvements to develop the parcels.
7. The location, width, name and approximate grade and curve radii of adjacent streets. The relationship of streets to any existing or proposed streets as shown on the City's Master Street Plan.
no city master plan
8. In addition, when all or part of the area encompassed in a partition application has not been previously included in a recorded plat (subdivision) of lots averaging a maximum of one-quarter acre each, the following information is also required: ?
9. In addition, when all or part of the area encompassed in a partition application has not been previously included in a recorded plat (subdivision) of lots averaging a maximum of one-quarter acre each, the following information is also required:
 - a. The certificate, stamp or seal of the Oregon registered professional land surveyor who prepared the tentative map plan.
 - b. The names of all recorded subdivisions next to the subject area.
 - c. The elevations of all points used to decide contours; said points given to true elevation above mean sea level from a benchmark elevation provided by the City Engineer within the general area of the project site. The base data shall be clearly shown and shall be compatible to City datum if benchmarks are not adjacent. The following intervals are required:

<u>Contour Intervals</u>	<u>Ground Slope</u>
One Foot	Up to 2%
Two Feet	Over 2% through 10%
Five Feet	Over 10%
 - d. The approximate width and location of all proposed public utility easements
 - e. The approximate location of areas subject to inundation or storm water overflow, all areas covered by water, and the location, width and direction of flow of all water course
 - f. All proposals for sewage disposal, flood control, and easements or deeds for drainage land, including profiles of proposed drainage ways
 - g. All public areas proposed to be dedicated by the partitioner (including reserve strips described in Section 6.02 of this ordinance) and the proposed uses of it.
 - h. All public improvements proposed to be made or installed, and the time within which improvements are envisioned to be completed.
 - i. A legal description of the boundaries of the entire area owned by the partitioner of which the proposed portion is a part
 - j.

↓
9

Where it is apparent that the subject parcel can be further partitioned, the divider must show that the land partition will not preclude the efficient division of land in the future

EXHIBIT D

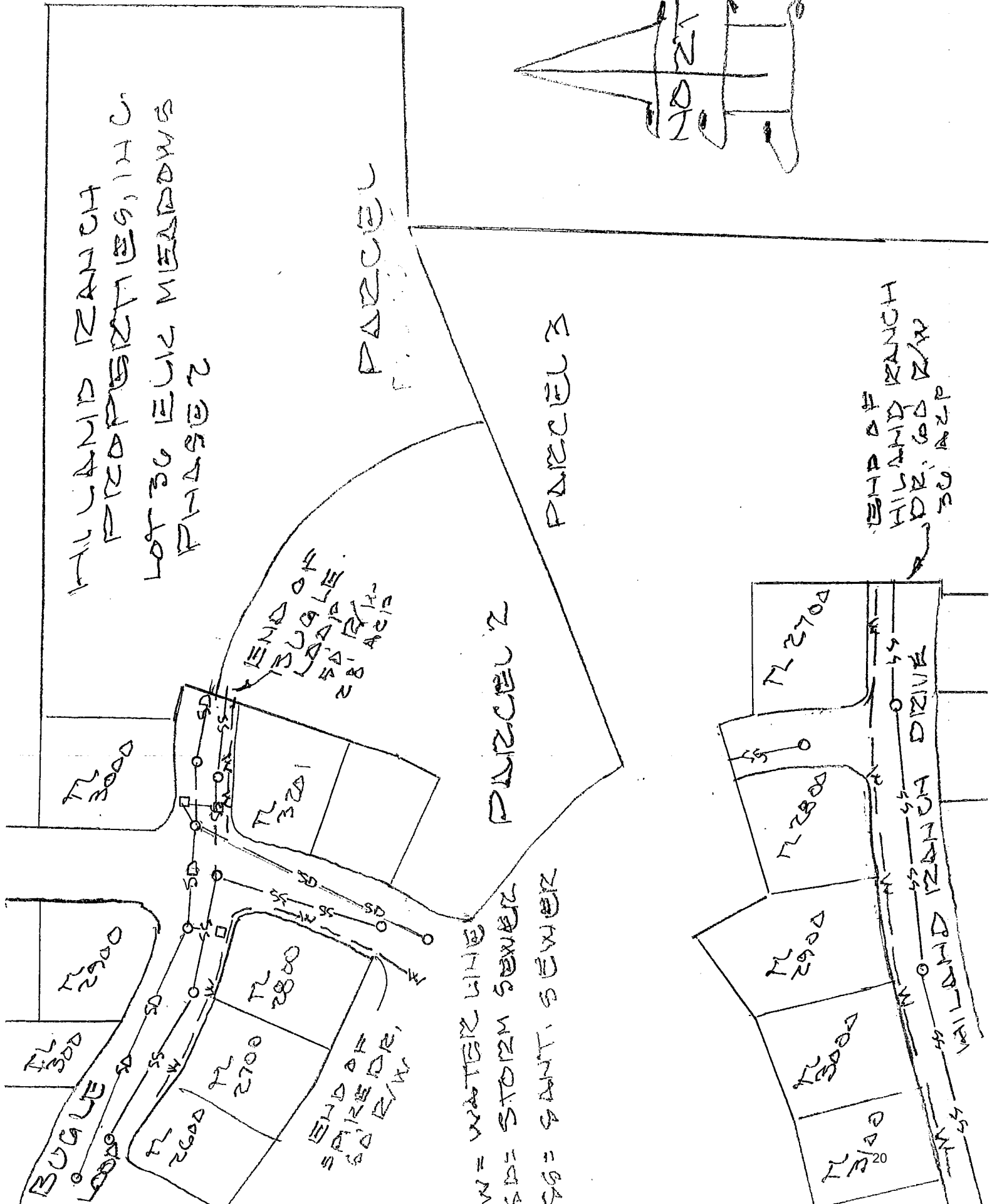
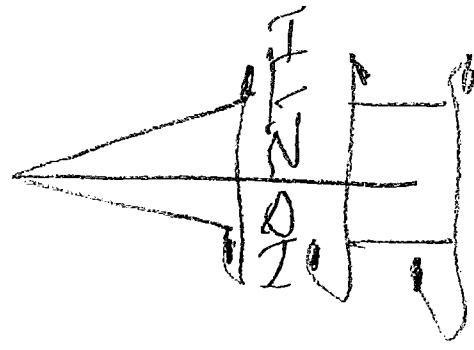

HILL AND RANCH HILL AND RANCH DRIVE, INC
LOT 30 EULK MEADOWS
PHASE 2

PARCEL 1

PARCEL 3

PARCEL 2

HILL AND RANCH HILL AND RANCH DRIVE, INC
LOT 30 EULK MEADOWS

END OF SUBLE
HILL AND RANCH DRIVE, INC

END OF SUBLE
HILL AND RANCH DRIVE, INC

W = WATER LINE
SD = STORM SEWER
SS = SANIT. SEWER

BUGLE LOOP

HILL AND RANCH DRIVE

30th AVE

2300

3200

22700

22800

2900

3000

2100

2900

300

2600

2700

2800

1. Names and addresses of the owners and anyone who has an interest in the property, as verified by a title company, and the applicant, engineer, surveyor or other parties involved in preparation of the tentative plan map
2. Approximate acreage of the land under a single ownership of, if more than one owner is involved, the total adjoining acreage of the owners directly involved in the partitioning
3. Any additional information as may be required by the City Planner or the Planning Commission to help in evaluating the request

ARTICLE 6- DESIGN STANDARDS

SECTION 6.01 DEDICATION

The Planning Commission may require adequate and proper streets to be dedicated to the public by the land developer. The streets shall be such design and in such location as are necessary to make provision for the transportation and access needs of the community, and the developed area according to the purpose of this ordinance.

SECTION 6.02 STREETS

- ① General. The location, width and grade of proposed streets shall be considered in their relation to existing and planned streets, to topographical conditions, to public convenience and safety, and to the proposed use of land to be served by the streets. The street system shall assure an adequate traffic circulation system with intersection angles, grades, tangents and curves appropriate for the traffic to be carried and considering the terrain. Where location is not shown in a development plan, the arrangement of streets shall either:
 - a. Provide for the continuation or appropriate extension of existing principal streets in the surrounding area; or
 - b. Conform to a plan for the neighborhood approved and adopted by the Planning Commission to meet a particular situation where topographical or other conditions make continuance or conformance to existing streets impractical.

2. Minimum Right-of-Way and Roadway Widths. The width of streets and roadways in feet shall be adequate to fulfill all City specifications, and shall not be less than the minimums shown in the following table.

<u>Type</u> of Street	<u>Right-of-Way</u> Width	<u>Paving</u> Widths
Arterials	60'	48'
Collectors	60'	36'
Local streets less than 1,200 feet	50'	28'
Local streets greater than 1,200 feet	60'	36'
Cul-de-sac bulbs	92'	70'

The actual width will be decided by the Planning Commission based upon nearby physical conditions, safety of the public, and the traffic needs of the community.

3. Reserve Strips. The control and disposal of the land in such strips shall be placed within the jurisdiction of the City under conditions approved by the Planning Commission.

4. Alignment. As far as is practical, streets other than minor streets shall be in alignment with existing streets by continuation of the center lines. Staggered street alignment resulting in "T" intersections shall, wherever practical, leave a minimum distance of 200 feet between the center lines of streets having approximately the same direction.
5. Future Extensions of Streets. Where necessary to give access to or allow a satisfactory future division of adjoining land, streets shall be extended to the boundary of the land division and the resulting dead-end streets must have a turn-around. Reserve strips may be required to preserve the objectives of street extensions.
6. Intersection Angles. Streets shall be laid out to intersect at right angles, and all other conditions shall require a variance. An arterial or collector street intersecting with another street shall have at least 100 feet of tangent next to the intersection.
7. Existing Streets. Whenever existing streets next to or within a tract of inadequate width, additional right-of-way shall be provided at the time of the land division.
8. Cul-de-sac. A cul-de-sac shall have a maximum length of 400 feet. It shall end with a circular turn-around.
9. Street Names. Except extensions of existing streets, no street name shall be used which will duplicate or be confused with the name of an existing street. Street names and numbers shall conform to the established pattern in the City and shall be subject to the approval of the Planning Commission.
10. Grades and Curves. Grades shall not exceed 10 percent on arterials, 10 percent on collectors and 15 percent on other streets, except that for short stretches not more than 200 feet in length, the grade may be 20 percent. Center line radii of curves shall not be less than 100 feet.
11. Special Safety Requirements. Where necessary to ensure safety, reduce traffic hazards and promote the welfare of the public, the Planning Commission may require that local streets be designed to discourage their use by non-local traffic.

SECTION 6.03 BLOCKS

1. General. The length, width and shape of blocks shall consider the need for adequate building site size and street width and shall recognize the limitations of the topography
2. Length. Block length shall not exceed 1,200 feet.
3. Easements.
 - a. Utility lines. Easements for sewers, water mains, electric lines or other public utilities shall be dedicated wherever necessary. The easements shall be at least 14 feet wide and located next to lot or parcel lines, except utility pole tieback easements that may be reduced to six feet in width
 - b. Water Courses. If a tract is traversed by a water course, such as a drainage way, channel or stream, there shall be provided a storm water easement or drainage right-of-way. The easement or right-of-way will conform, substantially with the lines of the water course, and will be of such further width as will be adequate to comply with the adopted drainage plan. Streets or parkways parallel to the major water courses may be required.
 - c. Pedestrian and Bicycle Ways. When desirable for public convenience a pedestrian or bicycle way may be required to connect to a cul-de-sac or to pass through an unusually long or oddly-shaped block or
 - otherwise provide appropriate circulation.

1. Size and Shape. The size, width, shape and orientation of building sites shall be appropriate for the location of the land division and for the type of development and use contemplated. Lots shall also comply with the following standards:
 - a. Width. Each lot shall have an average width between the lot side lines of not less than 50 feet. Each corner lot and each authorized key lot and butt lot shall have an average width between the lot side lines of not less than 55 feet.
 - b. Depth. Each lot shall have an average depth between the lot front and rear lines of not less than 80 feet and not more than 2-1/2 times the average width between the lot side lines. Each double frontage lot shall have an average depth between the lot front line and lot rear line of not less than 100 feet. However, a lesser depth may be approved by the Planning Commission if it is necessary because of unusual topographical conditions.
 - c. Area. Each lot shall be a minimum of 5,000 square feet, except in the case of planned unit developments.
 - d. Frontage. Except flag lots, each lot shall have frontage of not less than 35 feet upon a street. However, a lot on the outer radius of a curved street or facing the circular end of a cul-de-sac shall have frontage of not less than 35 feet upon a street, measured on the arc.
 - e. Where property is zoned and planned for business or industrial use, other widths and areas may be allowed at the discretion of the Planning Commission. Depth and width of properties reserved or laid out for commercial and industrial purposes shall be adequate to provide for the off-street service and parking facilities required by the type of use and development contemplated.
- (2) Through Lots. Through lots shall be avoided except where they are essential to provide separation of residential development from major traffic arteries or adjacent nonresidential activities or to overcome specific disadvantages of topography and orientation. A planting screen easement at least ten feet wide and ten feet across may be required along the line of building sites abutting a traffic artery or other incompatible use. There shall be no right of access within such an easement.
- (3) Lot Side Lines. The lines of lots, as far as is practical, shall run at right angles to the street upon which they face, except that on curved streets they shall be radial to the curve.

SECTION 6.05 GRADING OF BUILDING SITES

Grading of building sites shall conform to the following standards, the currently adopted Uniform Building Code and those of the Excavation and Grading Ordinance No. 707, unless physical conditions suggest the use of other standards.

ATTACHMENTS

Applicant shall prepare and attach the following to this application:

1. A presentation of facts and reasons which establish need, appropriateness and purpose of the Variance/Conditional Use request, and
2. An 8 1/2" x 11" location map of area subject to proposed Variance/Conditional Use drawn to scale, and
3. Either assessor's map, parcel map, or site plan drawn to scale showing proposed Variance/Conditional Use, and
4. A list of names and addresses of property owners** whose property is subject to the proposed Variance/Conditional Use or within 250 feet of the exterior boundary thereof, and
5. Other information specified in Section 4.2-9 of the Zoning Ordinance, and
6. Agreement by the property owner to satisfy the requirements of Section 4.2-9 of the Zoning Ordinance, if applicable.

**** NOTE:** This information available from the county assessor's office.

FEE

Refer to fee schedule adopted by City Council \$ 300.00

I, Steve Ness, PRES. HRP, (circle one: Landowner) Agent, Representative of Governmental Unit) swear that the details and information contained in the above application and attachments thereto are true and correct to the best of my knowledge.

 3-29-19
 Signature of Applicant Date

I, _____, City/County Official of _____
 attest that the foregoing application and attachments thereto were received by me on the
 _____ day of _____, 20____, from _____
 accompanied by a fee of \$ _____.

 City or County Official Date

Section 4.08 Signs

At this time the landowner does not see that any signs will be placed on the 3 proposed Parcels, but if there is a need for a sign the landowner will work with the City's staff to make sure that the proposed sign meets the City's code.

Section 4.09 Design and Placement of Standards for Manufactured Homes

The landowner will meet or exceed the requirements of this portion of the City's code for the placement of a manufactured home.

The below information are the names and addresses of the parcels within the 250 foot outward from the exterior boundary of TL 1300

21-35-09-40 TAX LOTS:

101- Mary Ann Leavitt Disclaimer Trust, 76667 Westoak Road, Oakridge, OR 97463
2600- Jerald & Susan Foster, 767005 Hazeldell Ct., Oakridge, OR 97463
2700- Robert Mickey, 48492 Hilland Ranch Drive, Oakridge, OR 97463

21-35-10-00 TAX LOTS:

800-Roberta Davis 1906 St Clair, Medford, OR 97504
902- James Anthony, P.O. Box 1507, Gold Beach, OR 97444
906- James Anthony, P.O. Box 1507, Gold Beach, OR 97444
905- James Anthony, P.O. Box 1507, Gold Beach, OR 97444
907- James Shafer, 48580 McFarland Road, Oakridge, OR 97463
1400- Alfred Wilson, 48584 McFarland Road, Oakridge, OR 97463

21-35-10-32 TAX LOTS:

3201- Larry Dimmick, 1534 SW Pine Drive, Warrenton, OR 97146
2800- David Magnuson, 670 White Oak Cir#210, Independence, OR 97351
2700- Hiland Ranch Properties, Inc. 2880 Arrowhead Str. Eugene, OR 97404
2600- Hiland Ranch Properties, Inc. 2880 Arrowhead Str. Eugene, OR 97404
2500- Hiland Ranch Properties, Inc. 2880 Arrowhead Str. Eugene, OR 97404
2400- Hiland Ranch Properties, Inc. 2880 Arrowhead Str. Eugene, OR 97404
2200- Hiland Ranch Properties, Inc. 2880 Arrowhead Str. Eugene, OR 97404
2100- Hiland Ranch Properties, Inc. 2880 Arrowhead Str. Eugene, OR 97404
3300- City of Oakridge, P.O. Box 1410, Oakridge, OR 97463
2000- Hiland Ranch Properties, Inc. 2880 Arrowhead Str. Eugene, OR 97404
1900- Hiland Ranch Properties, Inc. 2880 Arrowhead Str. Eugene, OR 97404
1800- Bari Hawkins, 48509 Cow Crossing Drive, Oakridge, OR 97463
1700- Jerry Snyder, 76781 Bugle Loop, Oakridge, OR 97463

1600- John Hooten, 11111 Katy Fwy, Ste 535, Houston, TX 77079
1500- Scott Peterson, P.O. Box 1234, Oakridge, OR 97463
1400- Kevin Mansfield, 53085 Riverview Drive, La Pine, OR 97739
1300- Kevin Mansfield, 53085 Riverview Drive, La Pine, OR 97739
1200- William Chaney, 53085 Riverview Drive, La Pine, OR 97739
1100- William Chaney, 53085 Riverview Drive, La Pine, OR 97739
1000- Lawrence Hayter, 84626 Hill Top Drive, Pleasant Hill, OR 97455
900- Joyce Pappel, P.O. Box 157, Sumpter, OR 97877
800- Kevin Mansfield, 53085 Riverview Drive, La Pine, OR 97739
700- Kevin Mansfield, 53085 Riverview Drive, La Pine, OR 97739
600- Joseph Brissette, P.O. Box 1222, Oakridge, OR 97463
500- Hiland Ranch Properties, Inc. 2880 Arrowhead Str. Eugene, OR 97404
400- Scott Peterson, P.O. Box 1234, Oakridge, OR 97463
300- Scott Peterson, P.O. Box 1234, Oakridge, OR 97463
200- James Thamer, 1880 Lincoln Street, Seaside, OR 93955
100- David Swack, P.O. Box 564, La Pine, Or 97739
2900- Avalos Zavala, 76332 Rainbow Street Space 29, Oakridge, OR 97463
3000- Susanna Fun Yee Lam Haines, 1146 Washington Street, Apt 4, Eugene, OR 97401

21-35-10-33 TAX LOTS:

300- Stanley Yarbrough, 7913 Ranch River Drive, Elverta, CA 95626
400- Randy Healea, 48499 Hiland Ranch Drive, Oakridge, OR 97463
500- Casey & Casey, LLC 37115 Immigrant Road, Pleasant Hill, OR 97455
600- Casey & Casey, LLC 37115 Immigrant Road, Pleasant Hill, OR 97455
700- Hiland Ranch Properties, Inc. 2880 Arrowhead Str. Eugene, OR 97404
800- John Bates, 76703 Bugle Loop, Oakridge, OR 97463
900- DJR Resources LLC, P.O. Box 2241, Jasper, OR 97438
1400- City of Oakridge, P.O. Box 1410, Oakridge, OR 97463
1000- Thomas Wood, 1199 North Terry Street, Space#383, Eugene, OR 97402
1100- Joseph Brown, 48523 Six Point Drive, Oakridge, OR 97463
1200- Casey & Casey, LLC 37115 Immigrant Road, Pleasant Hill, OR 97455
1300- John Hooten, 1111 Katy Fwy Ste 535, Houston, TX 77079
1500- Edward and Marie A Weber Rev Trust, 2888 Riverwalk Loop, Eugene, OR 97401
1600- Edward and Marie A Weber Rev Trust, 2888 Riverwalk Loop, Eugene, OR 97401
1700- Edward and Marie A Weber Rev Trust, 2888 Riverwalk Loop, Eugene, OR 97401
1800- Edward and Marie A Weber Rev Trust, 2888 Riverwalk Loop, Eugene, OR 97401
1900- Edward and Marie A Weber Rev Trust, 2888 Riverwalk Loop, Eugene, OR 97401
2000- Edward and Marie A Weber Rev Trust, 2888 Riverwalk Loop, Eugene, OR 97401
2100- Edward and Marie A Weber Rev Trust, 2888 Riverwalk Loop, Eugene, OR 97401
2200- Edward and Marie A Weber Rev Trust, 2888 Riverwalk Loop, Eugene, OR 97401
2300- Edward and Marie A Weber Rev Trust, 2888 Riverwalk Loop, Eugene, OR 97401
2400- Edward and Marie A Weber Rev Trust, 2888 Riverwalk Loop, Eugene, OR 97401
2500- Sharon Lose, 48590 Hiland Ranch Drive, Oakridge, OR 97463
2600- Charles Nichols, P.O. Box 1045, Oakridge, OR 97463

2700- Larry Haneke, P.O. Box 209, Oakridge, OR 97463
2800- Casey & Casey, LLC 37115 Immigrant Road, Pleasant Hill, OR 97455
2900- Casey & Casey, LLC 37115 Immigrant Road, Pleasant Hill, OR 97455
3000- Casey & Casey, LLC 37115 Immigrant Road, Pleasant Hill, OR 97455
3100- Casey & Casey, LLC 37115 Immigrant Road, Pleasant Hill, OR 97455
3200- Casey & Casey, LLC 37115 Immigrant Road, Pleasant Hill, OR 97455
3300- Casey & Casey, LLC 37115 Immigrant Road, Pleasant Hill, OR 97455
3400- Casey & Casey, LLC 37115 Immigrant Road, Pleasant Hill, OR 97455
3500- Casey & Casey, LLC 37115 Immigrant Road, Pleasant Hill, OR 97455
3600- Casey & Casey, LLC 37115 Immigrant Road, Pleasant Hill, OR 97455
3700- Casey & Casey, LLC 37115 Immigrant Road, Pleasant Hill, OR 97455
200- Adam Benner, 32267 Ame Lane, Cottage Grove OR 97424
4400- Hiland Ranch Properties, Inc. 2880 Arrowhead Str. Eugene, OR 97404
4500- Hiland Ranch Properties, Inc. 2880 Arrowhead Str. Eugene, OR 97404
4600- Jake Nosler, 76760 Bugle Loop, Oakridge, OR 97463
4700- Erik Nosler, P.O. Box 403, Oakridge, OR 97463
3800- Carlos Velez, 76773 Bugle Loop, Oakridge, OR 97463
3900- Michael Myers, 48454 East Meadow Way, Oakridge, OR 97463
4000- Eugene Furness Estate, 48341 High Leah, Drive, Oakridge, OR 97463
4100- Hiland Ranch Properties, Inc. 2880 Arrowhead Str. Eugene, OR 97404
4200- Hiland Ranch Properties, Inc. 2880 Arrowhead Str. Eugene, OR 97404
4300- Hiland Ranch Properties, Inc. 2880 Arrowhead Str. Eugene, OR 97404

21-35-15-00 TAX LOTS:

100- Oregon Department of Fish and Wildlife, 4034 Fairview Industrial Drive, SE,
Salem, OR 97302
103- FC Lands, LLC, 9570 SW Barbur Blvd Ste 315, Portland, OR 97219

21-35-16-11 TAX LOTS:

7500- Jake Burnham, P.O. Box 70374, Springfield, OR 97475
7600- Frances Jarvis, 13901 South Carrolton, Escalon, CA 95320
7700- Frances Jarvis Revocable Trust , 13901 South Carrolton, Escalon, CA 95320

ADDITIONAL INFORMATION:

- 1) EXHIBIT A is a copy of the vicinity map (not to scale)
- 2) EXHIBIT B is a copy of the typical x-section of the 28 foot road used for the 50 foot right of way;
- 3) EXHIBIT C is a copy of the typical x-section of the 36 foot road used for the 60 foot right of way;
- 4) EXHIBIT D is a copy of the existing utilities at the entrance to proposed Parcels 1 and 2.

Partition plus Lot Line Adjustment

rick@westoakgisplanning.com <rick@westoakgisplanning.com>
To: Rick Zylstra <rickzylstra@ci.oakridge.or.us>

Thu, Jul 9, 2020 at 7:05 AM

#1, Phil Newton is responsible for finding the surveyor to do the work needing done, please search for Phil Newton in my recent sent email box, you will find I sent him copies of the agreement which should have a description of the work needing done. Awaiting for him to get the surveyor, then the work needing done should be verified by the city as correct for both parties, once survey completed the city had agreed to pay for half of the cost.

* { #2 Steve Ness is needing to provide more info for a partition. The surveys that he turned in didn't have contour lines and didn't address stormwater concerns. He is trying to partition an area that is rather steep. Plus it didn't address utility installation, he claims he can't afford to install the utilities and spoke about a deed restriction that the costs would be deferred to any new owners. I am not fond of this idea but was willing to entertain the concept, but I never received anything in writing to verify how it would work, no details provided. Unfortunately Steve was not a big email user, so I have no emails to refer to.

On both of these projects I was willing and did work with the individuals, we are awaiting info from the property owners. Both project where being handled by the same surveyor, Don Nichols (I believe) but Phil got tired of waiting on Don and started searching for another surveyor.

I have no idea why Pat is pushing this issue, the properties are not hers nor is she the applicant, I feel I have shared more info than I probably should have with her. I have done all I could to move these projects forward but it they are needing work to be done by the property owners, not Pat.

[Quoted text hidden]

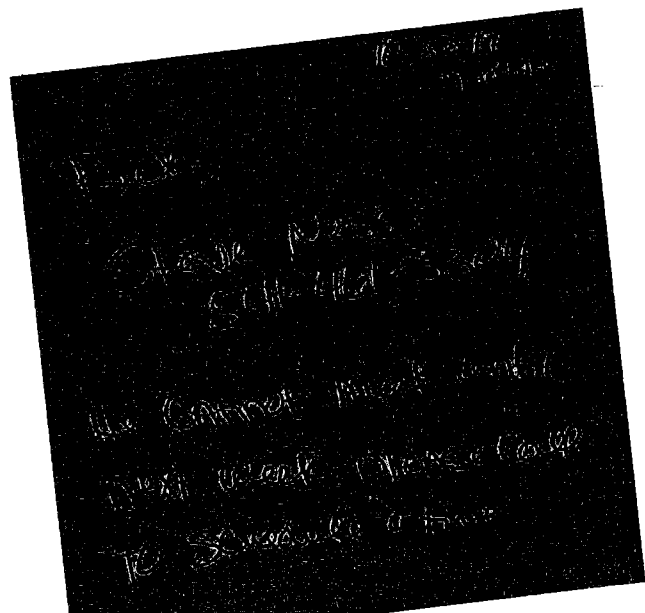
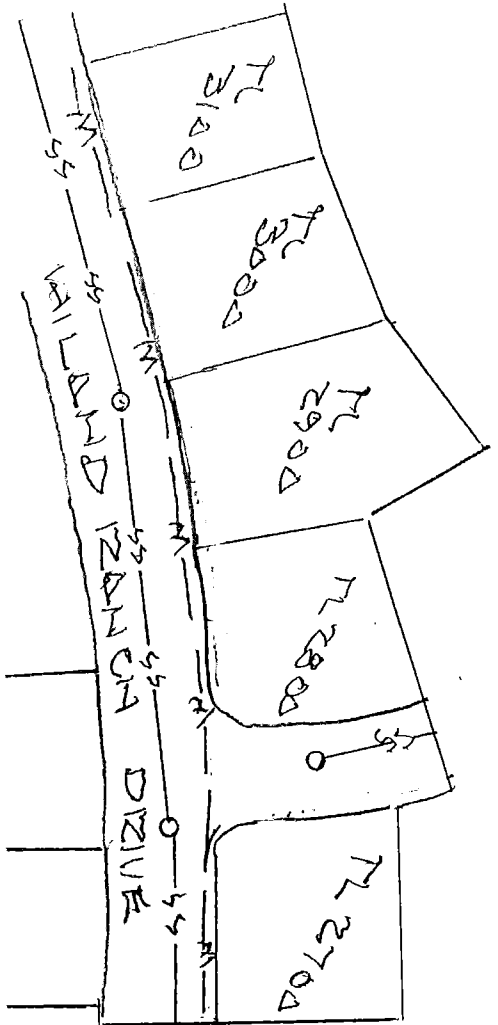
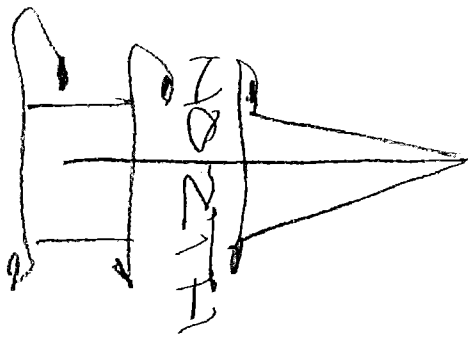
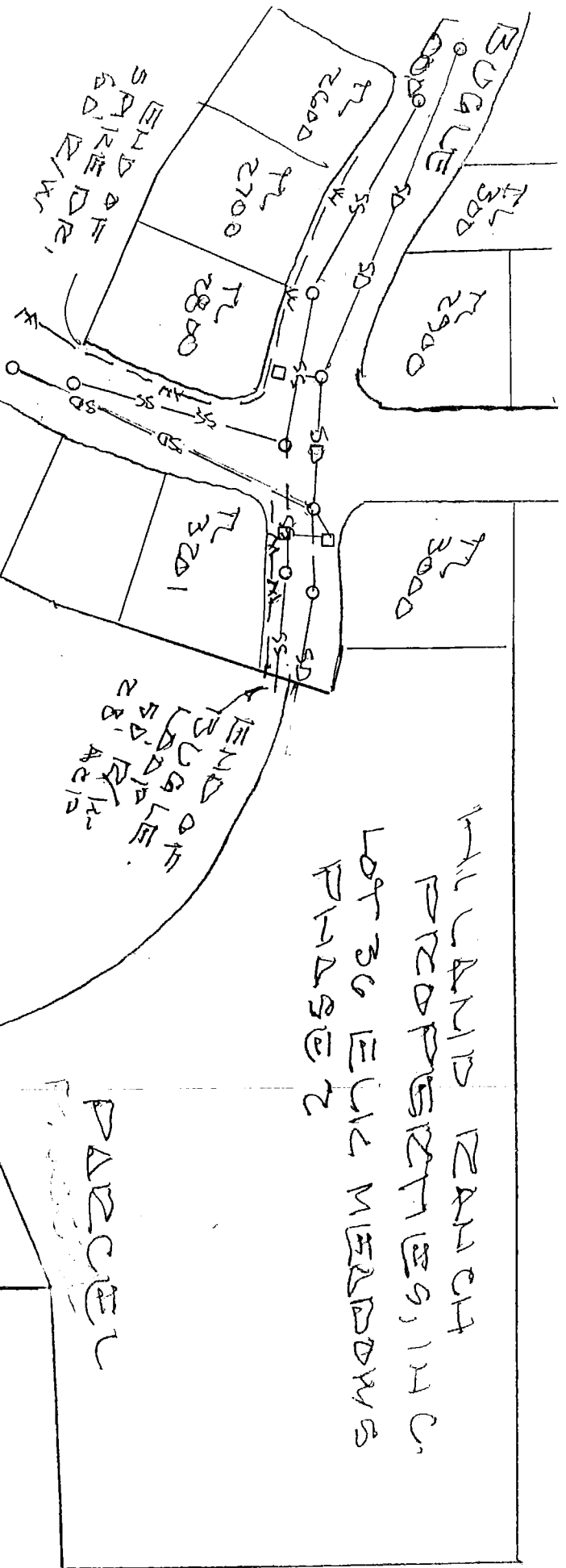

EXHIBIT D

HILL AND RANCH
PROPERTIES, INC.
LOT 30 ELEC MEADOWS
PHASE 2



HILL AND RANCH
DRIVE
30' WIDE

MAY 15, 2008

EXHIBIT A

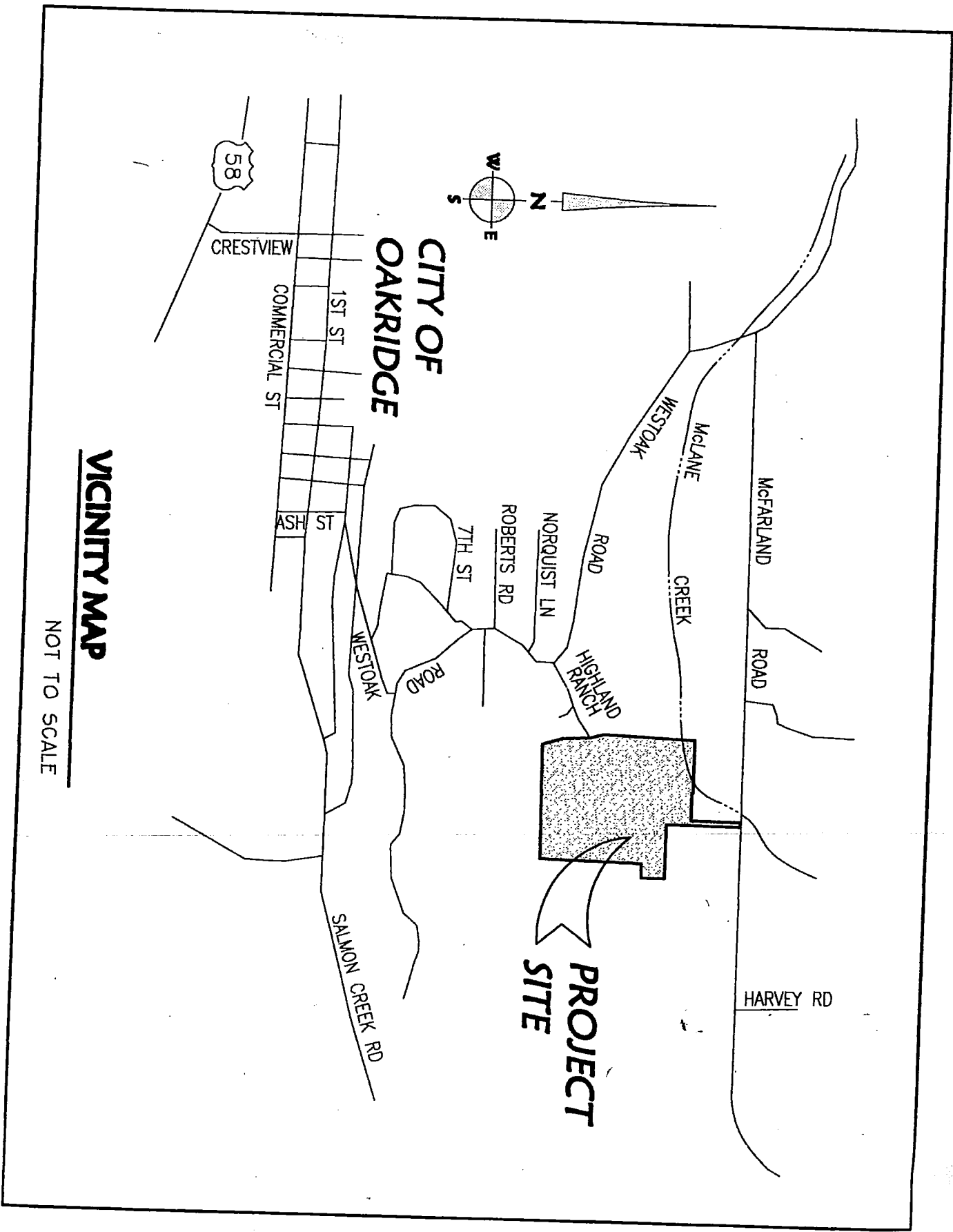

VICINITY MAP

NOT TO SCALE

- 1. A S
- 2. L A
- 3. C C
- S G
- C C
- T H
- A N
- P R

HILAND RANCH
PROPERTIES, INC.
LOT 36 BELIE MEADOWS
PHASE 2

PARCEL 1

END OF
TRAIL
AREA

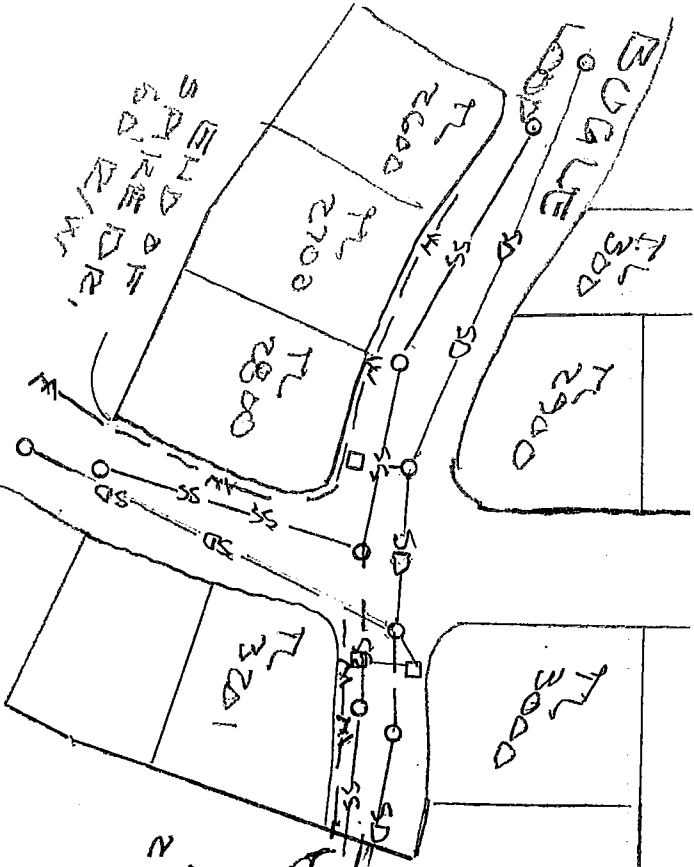

W = WATER LINE
SS = STORM SEWER
SS = SANDY SEWER

PARCEL 2

PARCEL 3

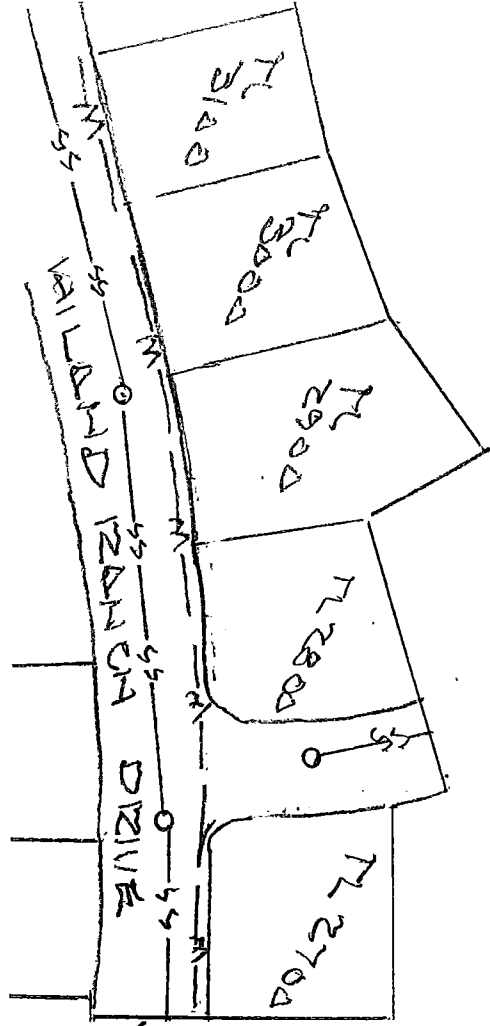

END OF
HILAND
RANCH
DRIVE, SANDY
SEWER

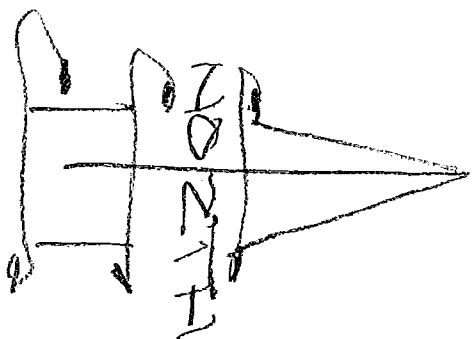

Proposed Elk Meadow Lot 36 Partition

This map presented here is for discussion purposes only and is in no way intended to be approval of proposed partition

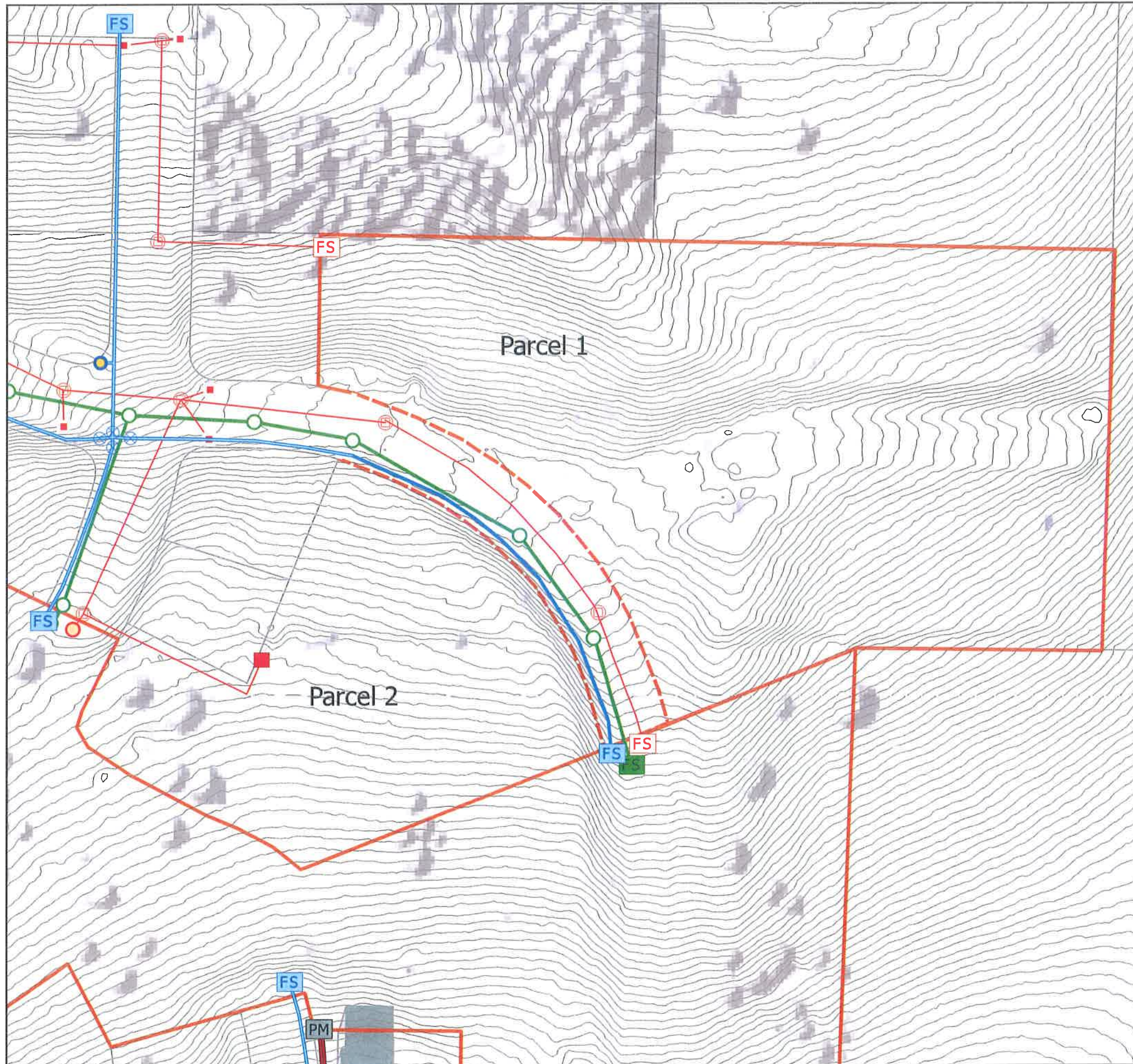

- Lot 36 proposed Partition
- Current Taxlots
- Water Future Stub
- Fire Hydrants
- Water Valve
- Water Line
- Storm Future Stub
- Storm Catch Basin
- Storm Curb Inlet
- Storm Cleanout
- Storm Line
- Open Channel
- Sanitary Future Stub
- Sanitary Lift Station
- Sanitary Gravity Line
- Sanitary Force Main
- Sanitary Manhole
- 1 foot Contours

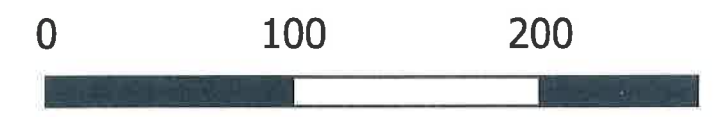

Proposed Elk Meadow Lot 36 Partition

This map presented here is for discussion purposes only and is in no way intended to be approval of proposed partition

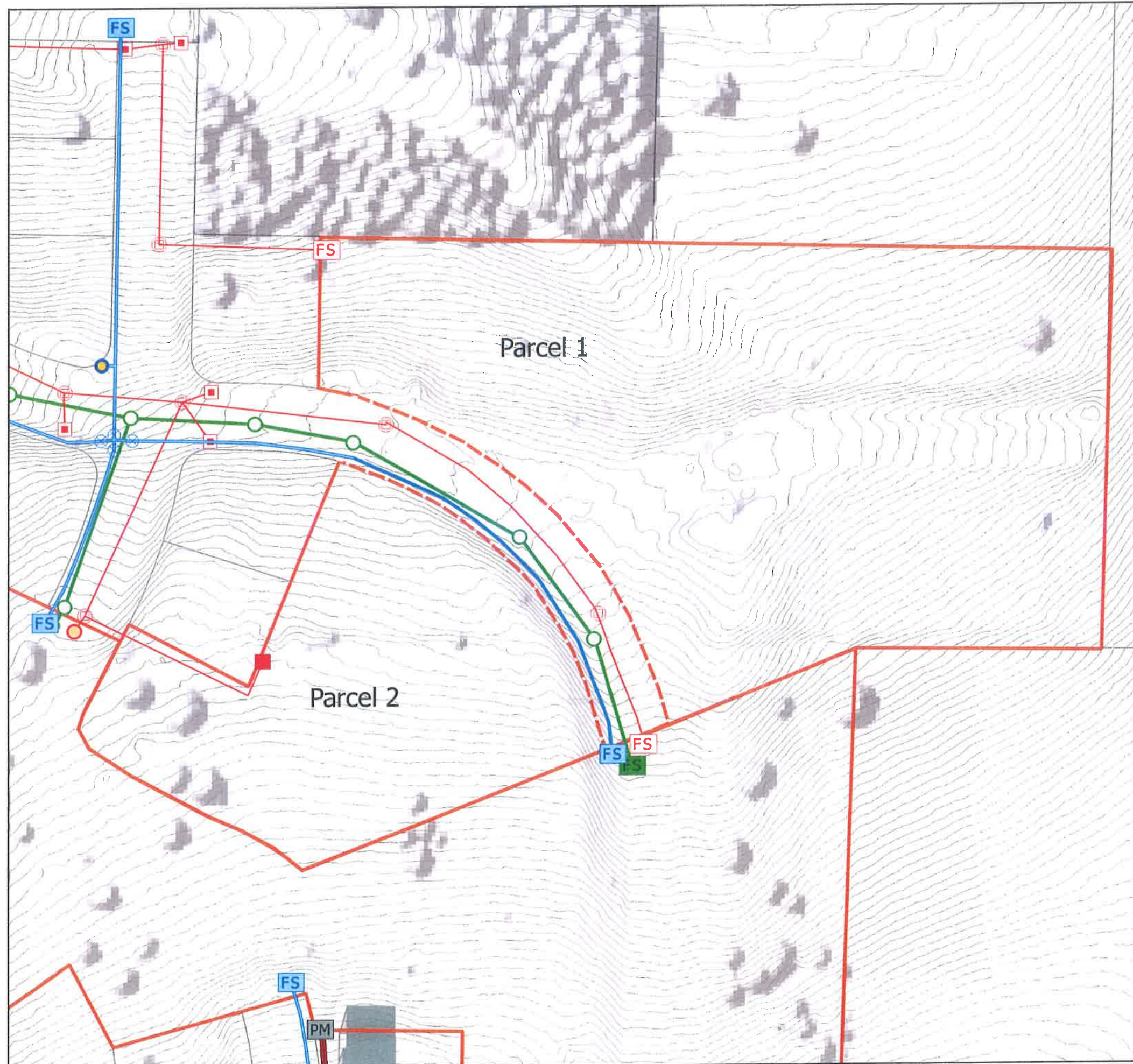

- Lot 36 proposed Partition
- Current Taxlots
- FS Water Future Stub
- Fire Hydrants
- ⊗ Water Valve
- Water Line
- FS Storm Future Stub
- Storm Catch Basin
- ▣ Storm Curb Inlet
- Storm Cleanout
- Storm Line
- >— Open Channel
- FS Sanitary Future Stub
- LS Sanitary Lift Station
- Sanitary Gravity Line
- Sanitary Force Main
- Sanitary Manhole
- 1 foot Contours

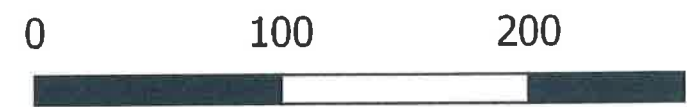

ATTACHMENT B

NOTEBOOM LAW LLC

November 12, 2020

Via First Class Mail

Henry Hearley
Lane Council of Governments
859 Willamette St, Ste 500
Eugene, OR 97401

Re: Supplemental Response to Notice of Incompleteness

Dear Henry:

I am writing on behalf of the applicant Hiland Ranch Properties Inc. which applied for an application to partition Lot 36, of the Elk Meadow subdivision in Oakridge, Oregon. Please accept this letter as Applicant's response to the notice of incompleteness issued July 13, 2020 and include a copy in the record. I look forward to working with you on this project.

BACKGROUND/PROPOSAL:

Applicant is providing the following background information to assist staff and the Planning Commission in processing the partition application. Elk Meadows subdivision encompasses approximately 69 acres of R-1 zoned property inside of Oakridge, Oregon consisting of 79 platted lots. The current development was approved through 3 phased subdivision applications with the last application approved on or about 2008. All phases are encumbered by recorded CC&R which impose certain restrictions for the benefit of the residential properties. Consistent with Oakridge's development code, each approved phase is serviced with water, power, sewer and paved streets. The remaining undeveloped property, Lot 36 is serviced with all-weather gravel roads with water, power and sewer terminating at the boundaries of the existing developed portion of Elk Meadows and Lot 36. The original development concept envisioned further phased subdivision plats to fully develop the remaining vacant Lot 36 (approx. 39.28 acres) into 121 additional residential lots. As the property was to be further subdivided, additional infrastructure would be built out to service those new lots.

As history has shown, the difficulty with that approach is that it front loads the cost of all infrastructure for a very large property and then slowly recoups the infrastructure cost through the subsequent sale of residential lots. That model is not economically viable to develop the remainder of Lot 36. Instead, Applicant is proposing a less aggressive approach, where Lot 36 would be partitioned into 2 larger parcels which would accommodate a single family residence and which, at the election of the property owners, could be further partitioned or subdivided at some future time when demand warrants. The third parcel would be a remainder parcel to be further partition/subdivided at a future time. No residence is proposed for the remainder parcel. Applicant would reserve across the various newly partitioned parcels

easements for utilities (power, water, sewer) and access that would mirror the original planned location for those facilities for Elk Meadows facilitating future development. Additionally, the two newly partitioned lots would be encumbered by the same CC&R ensuring both uniformity with existing development and prohibiting incompatible uses that would conflict with future partition or subdivision. Applicant is proposing that the newly partitioned parcels would take access from the terminus of the existing paved roads abutting the property and hook into existing water, power and sewer at that same location. Future applications seeking to further partition or subdivide the two newly created parcels would be subject to City requirements for improving/extending services (e.g. roads, sewers, power, curbs, stormwater, etc.). Assuming this process proves successful, it could be replicated to develop the remainder of Lot 36. An illustration of this process follows:

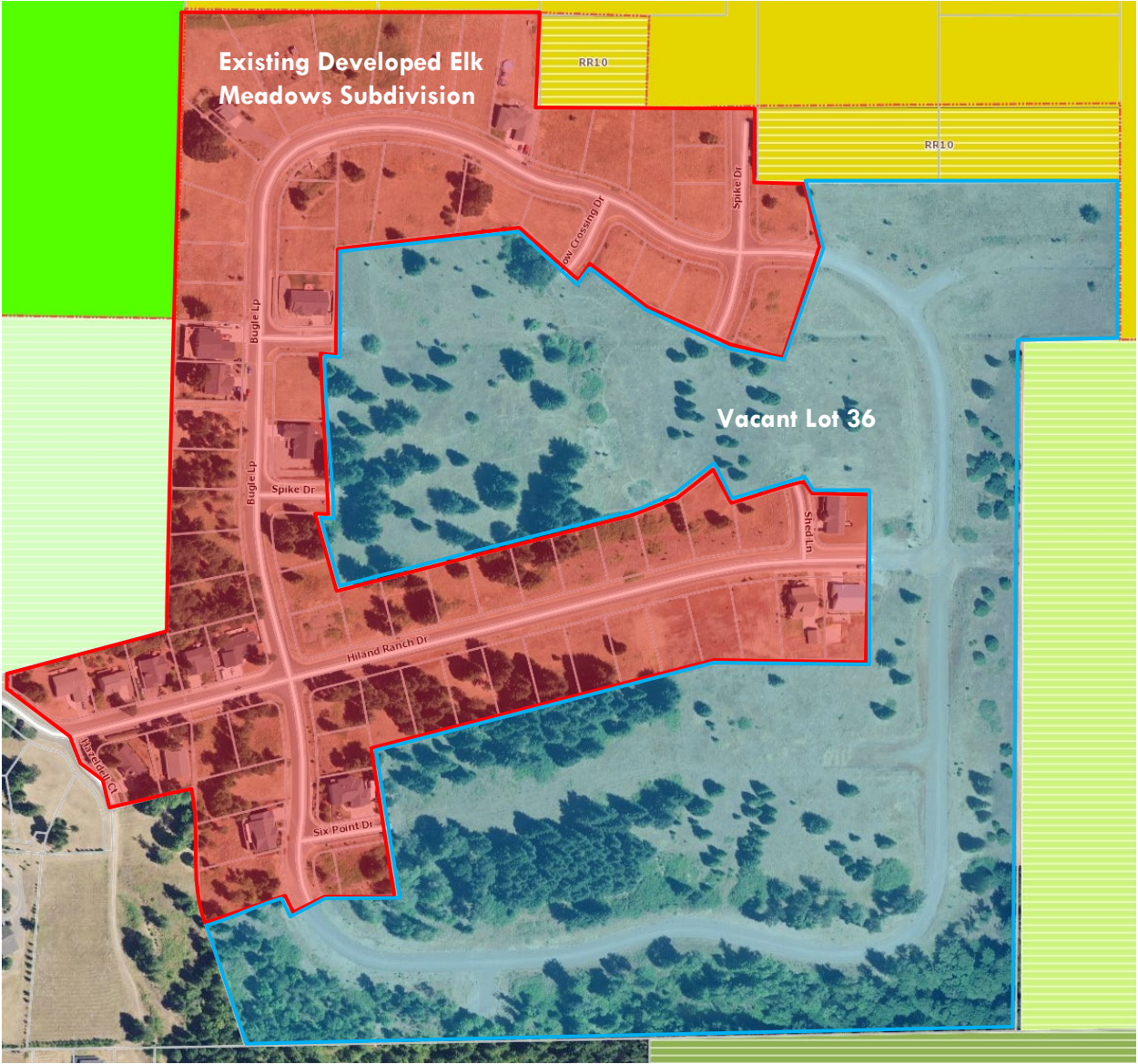

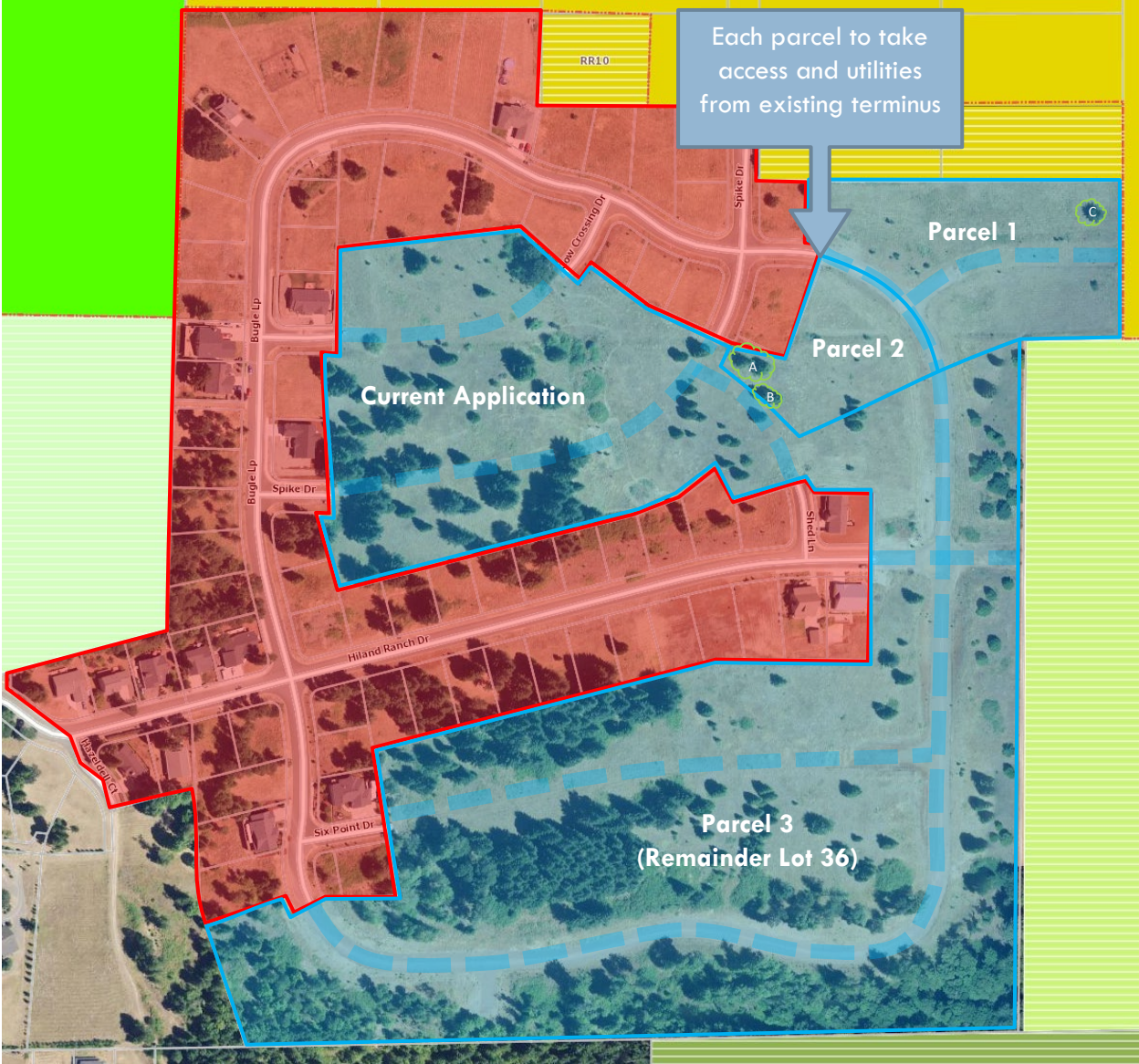

Trees:

- A - 1 x 16" Incense Cedar, 4 x 12" Incense Cedar
- B - 10 +/- x 6"-10" Incense Cedar
- C - 1 x 12" Doug Fir



151.063 Information on Tentative Plan Map. The following information shall be contained on or with the tentative plan map:

151.063 (D) Location of buildings on the tract and within 25 feet of the property line of the tract, slope of land, trees with a trunk diameter at chest height of six inches or greater and other features of the land important to its development.

RESPONSE: For purposes of this section, staff has requested information regarding the proposed Parcel 1 and Parcel 2. There are no building on or within 25 ft of the property lines for Parcel 1 or Parcel 2. The land generally slopes to the north east. There are only handful of trees on the property of chest height with a

diameter of six inches (shown in green on "Current Application" image above). The only developed feature on the property is the all-weather gravel access road forming Bugle Loop.

151.063 (E) Proposed improvements such as pavements, curbs and gutters, sanitary and storm sewers, sidewalks, bikeways, grading and filling and other major improvements to develop the parcels.

RESPONSE: No improvements are being proposed per the Background/Proposal above. Proposed Parcel 1 and Parcel 2 will connect to the terminus of the existing developed Bugle Loop road and existing power, water and sewer.

151.063 (H)(3) The elevations of all points used to decide contours; the points given to true elevation above mean sea level from a benchmark elevation provided by the City Engineer within the general area of the project site. The base data shall be clearly shown and shall be compatible to city datum if benchmarks are not adjacent. The following intervals are required:¹**

(a) A contour interval of one foot: ground slope of up to 2%;

RESPONSE: N/A

(b) A contour interval of two feet: ground slope of over 2% through 10%; and

RESPONSE: N/A

(c) A contour interval of five feet: ground slope of over 10%.

RESPONSE: Applicant will use the contour interval from the Tentative Plan for the Elk Meadow subdivision submitted herewith.

151.063 (5) The approximate location of areas subject to inundation or storm water overflow, all areas covered by water, and the location, width and direction of flow of all water courses

RESPONSE: None.

151.063 (6) All proposals for sewage disposal flood control and easements or deeds for drainage land, including profiles of proposed drainage ways.

RESPONSE: None.

151.063 (7) All public areas proposed to be dedicated by the partitioner, including reserve strips, and the proposed uses of it.

RESPONSE: Applicant proposes granting and reserving 50ft wide access and utility easements for the use and enjoyment of all partitioned property including Parcel 1, Parcel 2 and Parcel 3 (remainder Lot 36) and their further subdivision or partition. Easement locations are generally shown in dashed blue line on

¹ ** Because Lot 36 is part of a previously approved subdivision, the requirements of 151.063(H) are not approval criteria but responses are nevertheless provided to inform staff and the Planning Commission.

"Current Application" image. These easements would mirror the originally contemplated dedications for the full development of the property allowing for future development including fully improving the proposed easements (e.g. installation of sewer, paving of road) and possibly could be dedicated to the City.

151.063 (8) All public improvements proposed to be made or installed, and the time within which improvements are envisioned to be completed.

RESPONSE: No public improvements proposed for current partition application. Public improvements to be extended and/or made such Parcel 1 or Parcel 2 be further partitioned or subdivided into residential lots.

151.063 (9) A legal description of the boundaries of the entire area owned by the partitioner of which the proposed portion is part of.

RESPONSE: Lot 36 of Phase II, ELK MEADOWS SUBDIVISION as recorded in Lane County Official Records 2007-068321

151.063 (10) Where it is apparent that the subject parcel can be further partitioned, the divider must show that the land division will not preclude the efficient division of land in the future.

RESPONSE: The granting and reservation of easements and subjection of CC&R's ensure that the land is not precluded from the efficient future division in the future.

A shadow plat will be helpful to see how the parcels can be further developed.

RESPONSE: See attached Shadow Plat of Anticipated Future Partitions.

151.064 Additional Information and Documents. The following additional information and documents shall also be provided with the partition application:

(A) Names and addresses of the owners and anyone who has an interest in the property, as verified by the title company, and the applicant, engineer, surveyor or other parties involved in preparation of the tentative plan map.

RESPONSE:

Property Owner/Applicant: Hiland Ranch Properties, Inc.,
2880 Arrowhead St
Eugene, OR 97404.

Surveyor: Don Nickell
Nickell Land Surveying and Planning LLC
33225 Craig Lp
Cottage Grove, OR 97424

Legal Counsel: Aaron Noteboom
Noteboom Law LLC
375 W 4th Ave, Ste 204
Eugene, OR 97401

(B) Approximate acreage of the land under a single ownership of, if more than one owner is involved, the total adjoining acreage of the owners directly involved in the partitioning.

RESPONSE: Approx. acreage: Lot 36 - 39.28 acres, Lot 73 - .17 acres, Lot 74 - .19 acres, Lot 6 - .33 acres.

(C) Any additional information as may be required by the City Planner or the Planning Commission to help in evaluating the request.

No action required on behalf of the applicant pursuant to subsection (C), above. This statement is provided for informational purposes. Staff notes ORS 227.178 (2) (a-c) does apply to this provision.

RESPONSE: See Background/Proposal narrative.

151.080 Dedication.

The Planning Commission may require adequate and proper streets, pedestrian facilities, and bikeways to be dedicated to the public by the land developer. The streets shall be a design and, in a location, as are necessary to make provision for transportation and access needs of the community and the developed area according to the purpose of this chapter.

No specific action required by applicant to this provision at this time. The inclusion of this provision is to alert the applicant/developer that certain public improvements may be required before final acceptance of the tentative plat.

151.081 Streets.

Staff sees the applicant's submittal of Exhibits "B" and "C". Staff require a more detailed explanation and picture of the streets to be proposed and/or, that are involved, for the proposed partition.

RESPONSE: No new streets are currently being proposed in connection with this partition application to create to large residential lots. Future and further subdivision or partition of the proposed Parcel 1 or Parcel 2 may require such improvements. Easements will be granted and reserved to allow for such street improvement if necessary. Exhibit B and C show the build out of the existing streets with the developed portion of the property (e.g. Bugle Loop).

Please provide a written narrative how the proposal complies with street standards.

RESPONSE: No streets are required as the proposal is to create two residential lots which will take access from the terminus of the existing street.

Which entrances into Lot 36 is the applicant proposing to extend?

RESPONSE: No extension is proposed with this application.

A more detailed tentative plan map showing the extension of streets into Lot 36 may be helpful. This will also be beneficial to show on the shadow plat.

RESPONSE: See attached Shadow Plat of Anticipated Future Partitions.

If the applicant intends to place one single-family home on each lot, please describe how legal access to the home site will be achieved.

RESPONSE: Each parcel will touch/front Bugle Loop across approximately 25 feet. Access will be taken from the terminus of Bugle Loop.

Staff will include the City Engineer/Public Works into the discussion and review of certain specific street standards and details.

151.086 Large Building Sites.

(A) In dividing tracts into large lots or parcels that at some point are likely to be re-divided into smaller parcels approaching the minimum standards of this chapter, the land divider shall show the small parcel division by means of dashed lines showing future parcel divisions and streets. Buildings or structures shall be located within the small parcel areas with minimum yards or setbacks as specified within this chapter as though the development were occurring on the smaller parcel.

(B) This will simplify future land divisions and guarantee that existing buildings or structures will meet the locational requirements of this chapter.

The applicant can take this section to mean a "shadow plat" shall be required to show division of large tracts of land into buildable sites/parcels.

RESPONSE: See attached Shadow Plat of Anticipated Future Partitions.

151.103 Improvements in Partitions.

The same improvements may be installed to serve each building site of a partition as is required of a subdivision. However, if the Planning Commission finds that the nature of development near the partition makes installation of some improvements unreasonable, the Planning Commission may except those improvements. Instead of excepting an improvement, the Planning Commission may recommend to City Council that the improvement be installed in the area under facility extension policies of the city.

The provision is included to inform the applicant. No specific action is required for completeness. However, if the applicant/developer has real and serious reservations regarding the ability to provide public improvements, in that they would be unreasonable, the applicant is welcome to opine a statement to city decision makers. Ultimately, the issue will be decided by Planning Commission.

RESPONSE: Applicant is proposing the more limited partitions into large residential parcels (versus subdivision into standard residential .1-.2 acre lots) to take advantage of existing infrastructure. No additional street extension, sewer extension, power or water extensions are necessary to accommodate this limited development. Should further partition or development of those newly created Parcel 1 or Parcel 2

be proposed to allow for additional residential development, it may be necessary to require extension of existing infrastructure at that time.

Storm water/ Drainage.

Generally, please describe how the applicant proposes to deal with storm-water runoff/drainage. Staff invite Public Works and the City Engineer in on the discussions surrounding storm-water runoff/drainage.

RESPONSE: The partition application does not propose installation of any new impervious surfaces. No change to existing conditions necessitating storm water facilities.

PDF Copy of Tentative Plan/Map.

While not required by Code, if the applicant has a PDF copy of the Partition Tentative Plan/Map, it would be useful to provide to staff, for purposes of sharing electronic documents with affected agencies.

A 11x17 copy of the Partition Tentative Plan/Map would also suffice.

RESPONSE: Attached with PDF copies to follow by email.

Sincerely,

NOTEBOOM LAW, LLC



Aaron J. Noteboom

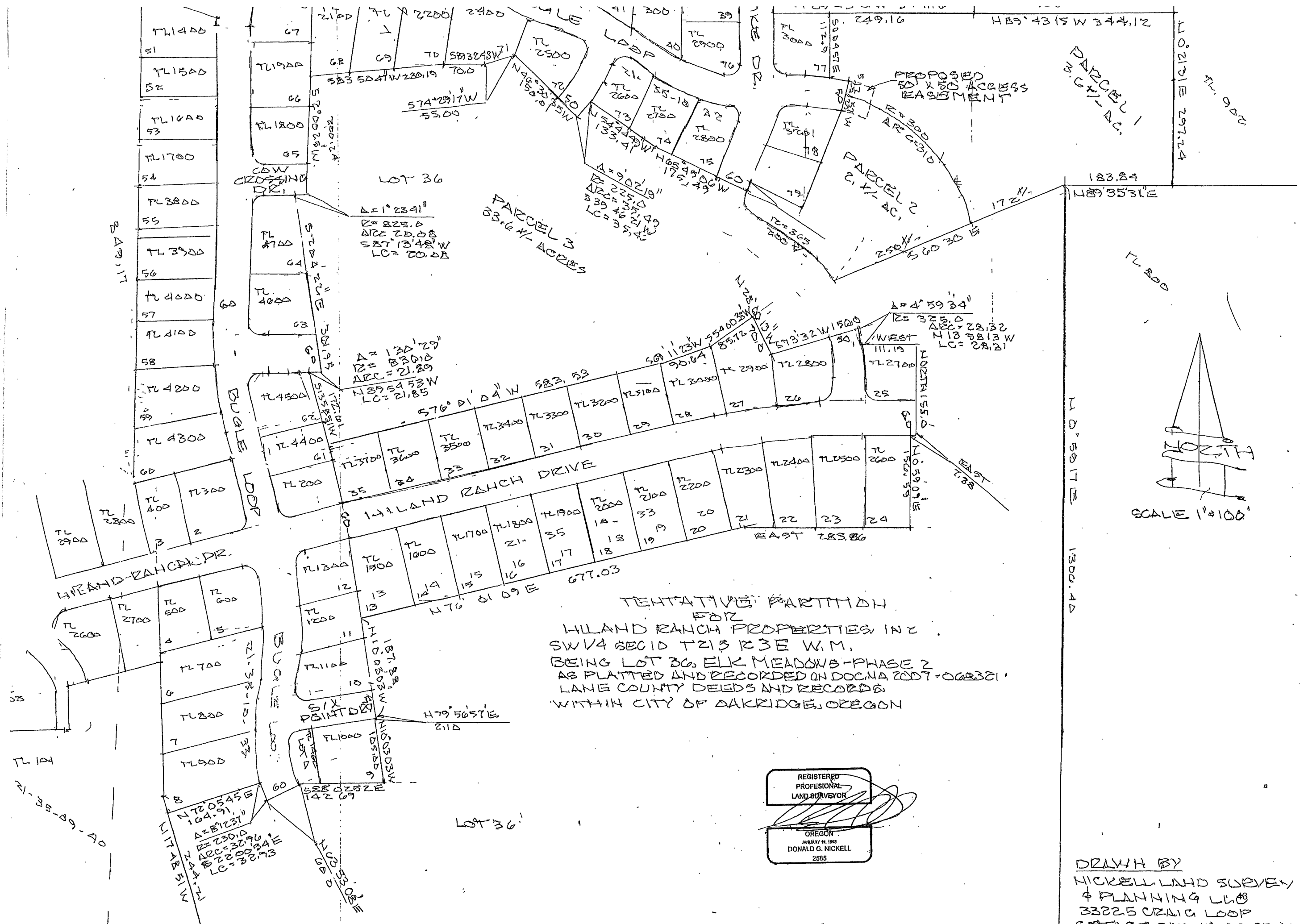

TENTATIVE PARTITION
 FOR
 HIGHLAND RANCH PROPERTIES IN
 SW 1/4 SEC 10 T21S R3E W1M,
 BEING LOT 36, ELK MEADOWS - PHASE 2
 AS PLATTED AND RECORDED ON DOC. NO. 2007-008321,
 LANE COUNTY DEEDS AND RECORDS,
 WITHIN CITY OF DAKRIDGE, OREGON

REGISTERED
 PROFESSIONAL
 LAND SURVEYOR

(Signature)

OREGON
 JANUARY 18, 1903
 DONALD G. NICKELL
 2585

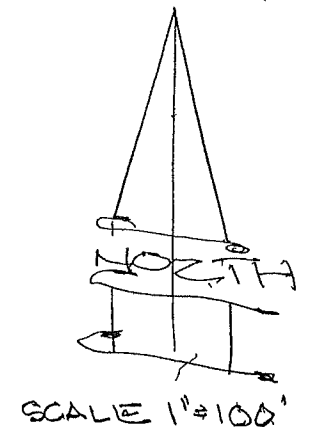

DRAWN BY
 NICKELL LAND SURVEY
 & PLANNING LLC
 33225 CRAIG LOOP
 COTTAGE GROVE, OR 97477

TENTATIVE SUBDIVISION PLAT

FOR
C.J. DEVELOPMENT CO.
OF
ELK MEADOWS
200 LOT SUBDIVISION

LOCATED IN
TAX LOT 900, 903, & 904, MAP 21-35-10,
SECTION 10, T. 21 S., R. 3 E., W.M.,
LANE COUNTY, OREGON
AUGUST 23, 2006

LEGEND (PROPOSED):

- WL — PROPOSED WATER MAIN
- FH — PROPOSED FIRE HYDRANT
- SD — PROPOSED STORM DRAIN
- CI — PROPOSED CURB INLET
- SS — PROPOSED SANITARY SEWER
- SS/FM — PROPOSED SANITARY SEWER FORCE MAIN
- MH — PROPOSED MANHOLE (SEWER OR STORM DRAIN)
- FG — PROPOSED STREET & FINISHED GRADE, ALL GRADE BREAKS SHALL HAVE A VERTICAL CURVE TRANSITION, LENGTH TO BE DETERMINED DURING FINAL DESIGN
- SG — PROPOSED FINISHED GRADE OF STREET + DIRECTION OF FLOW

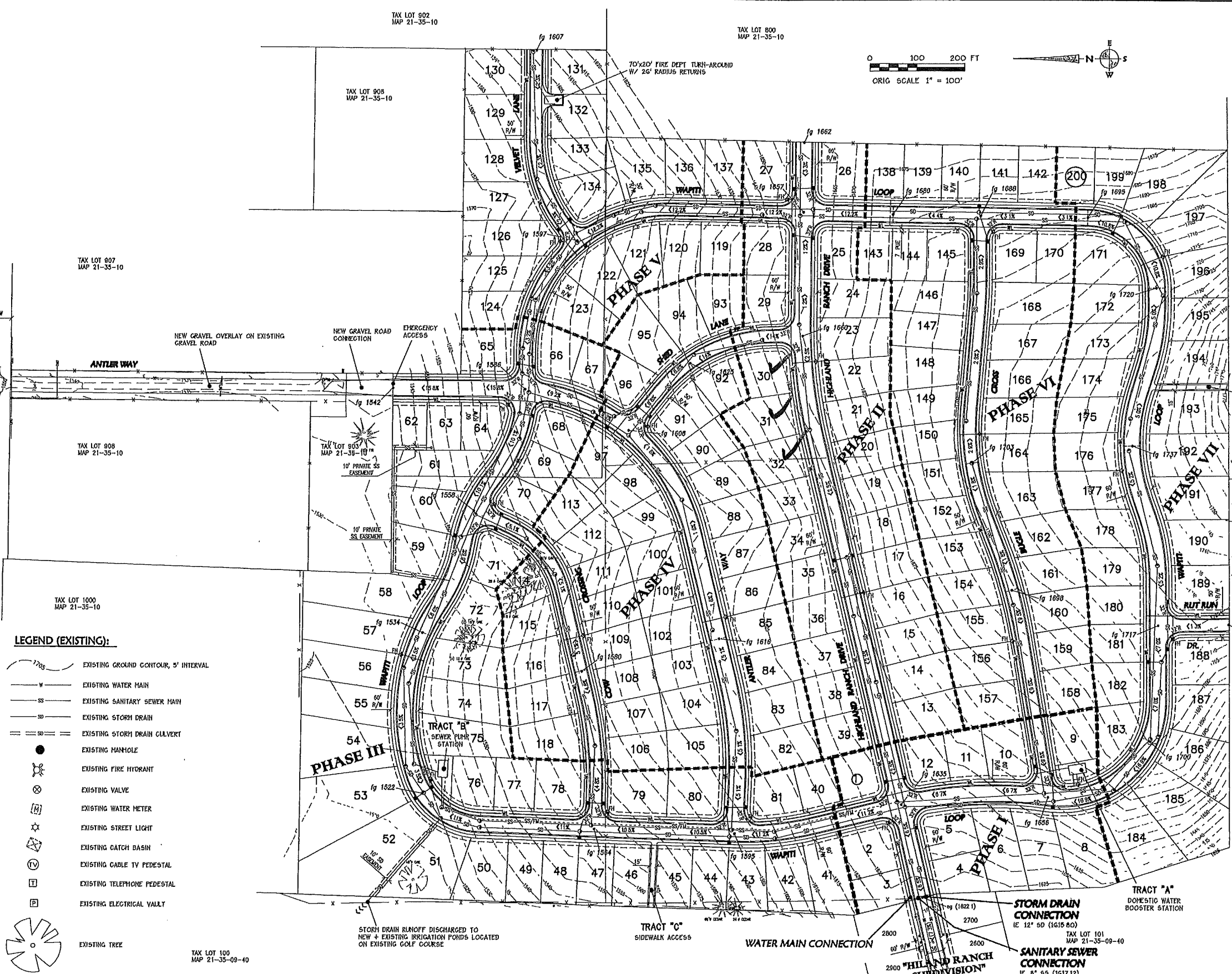
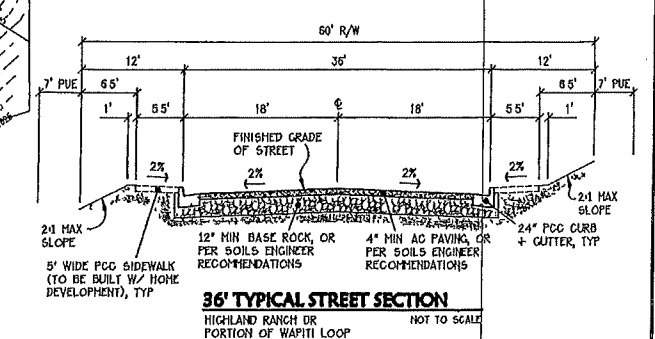
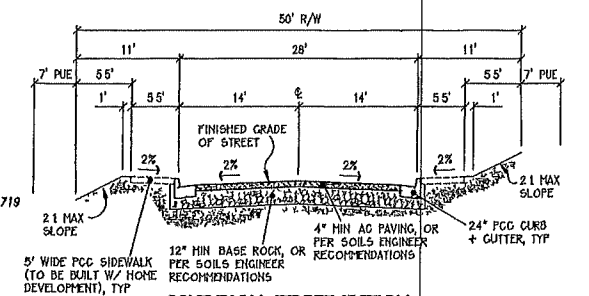

LEGEND (EXISTING):

- 1705 — EXISTING GROUND CONTOUR, 5' INTERVAL
- W — EXISTING WATER MAIN
- SS — EXISTING SANITARY SEWER MAIN
- SD — EXISTING STORM DRAIN
- SD — EXISTING STORM DRAIN CULVERT
- MH — EXISTING MANHOLE
- FH — EXISTING FIRE HYDRANT
- V — EXISTING VALVE
- M — EXISTING WATER METER
- S — EXISTING STREET LIGHT
- CB — EXISTING CATCH BASIN
- P — EXISTING CABLE TV PEDESTAL
- T — EXISTING TELEPHONE PEDESTAL
- E — EXISTING ELECTRICAL VAULT
- T — EXISTING TREE

Date: 8/23/2006 Time: 11:56
Scale: 1"=100'(FS)
Plot: dsg\2006\06-70\0670pre2.dwg (abwkedm)

THIS DOCUMENT, DESIGNS, & IDEAS INCORPORATED HEREIN, AS AN INSTRUMENT OF PROFESSIONAL SERVICE, IS THE PROPERTY OF K&D ENGINEERING, INC. AND IS NOT TO BE USED, IN WHOLE OR IN PART, FOR ANY OTHER PROJECT WITHOUT THE WRITTEN AUTHORIZATION OF K&D ENGINEERING, INC.

DATE	FEV 11 2006	BY	
------	-------------	----	--

K & D ENGINEERING, INC.
276 N.W. HICKORY STREET
P.O. BOX 725
ALBANY, OREGON 97321
(541) 928-2583

ELK MEADOWS
TENTATIVE MAP
CITY OF CAMBRIDGE, LANE COUNTY, OREGON

STREET & UTILITY
CONCEPT

HORIZ SCALE	1" = 100'	SHEET No.	2
VERT SCALE		OF	2
SIGN DATE			
DSGN BY	GB		
DRWN BY	DM		
CHK BY	GB		
PROJECT No.	06-10		

January 8, 2021

Via Email

Henry Hearley
Lane Council of Governments
859 Willamette St, Ste 500
Eugene, OR 97401

Re: Supplemental Response to Lot Standards and Proposed Recommendations.

Dear Henry:

I am writing to provide Applicant's supplemental response to the lot standards and to the City Engineer's proposed recommendations.

1. Lot Standards.

As you pointed out, the R-1 zone in Ordinance 847 contains the following standard:

"(3) Lot Dimensions. Except for flag lots and townhouse developments, the minimum lot width at the right-of-way shall be 30 feet, except corner lots that shall be a minimum of 50 feet wide. The maximum lot depth shall be no greater than three (3) times the lot width except as may be necessary to protect sensitive areas or address topographic limitations."

RESPONSE: As a threshold matter, Ordinance 847 recognizes the distinction between a "lot" created pursuant to a subdivision and a "parcel" created pursuant to a partition. Article 33 defines "lot" as "A lot is a unit of land that is created by a subdivision of land (ORS 92.010(3))." While Article 33 defines "parcel" as "A parcel is a unit of land that is created by a partitioning of land (ORS 92.010(6))." By its plain terms, the standard applies only to lots created by a subdivision in the R-1 zone and is therefore, not applicable to this partition application.

Nevertheless, should the standard be found to apply to this application, each of the proposed parcels meets this requirement. Important to this analysis is the definition of "right-of-way" in Article 33 which is defined as follows:

"Right-of-way: An area or strip of land, either public or private, on which an irrevocable right-of-passage has been recorded for the use of vehicles or pedestrians or both."

In this case, each of the new parcels will exceed the 30 feet requirement by virtue of either the access and utility easement (Parcels 1, Parcel 2 and Parcel 3) or abutting the terminus of existing streets (Parcel 3). For

example, Parcel 1 and Parcel 2 will have a minimum parcel width that runs the entire length of the access easement bisecting the two parcels (approximately 300 ft +/-). Parcel 3 will have access along the 50 ft terminus of the easement where it abuts Parcel 3. That access easement qualifies as a "right-of-way" under Article 33 or Ordinance 847. Parcel 3 will also have access along the terminus of Bugle Loop, Six Point Drive, Hiland Ranch Drive, Spike Drive, Cow Crossing Drive and Shed Lane. Each of those road right-of-ways are in excess of 30 ft wide.

2. City Engineer Proposed Recommendations.

As discussed in prior submissions, the large size of the property creates a very practical difficulty in developing the remaining property with a traditional subdivision complete with streets, sidewalks, power, water and sewer given the substantial upfront cost of installation and rate of subsequent sales/absorption. Instead, the Applicant has proposed utilizing a series of partitions to create larger parcels taking advantage of existing infrastructure which parcels could be further divided at some future time to include installation of the aforementioned infrastructure at that time. Each partition would create two parcels to be developed with a residence on each parcel and a remainder parcel (without a residence) to potentially be further partitioned (or subdivided) as some future time. All new residential parcels would abut and take access to and utilities from the terminus of an existing paved street to include sewer, water and power. There are a total of 9 such paved terminuses allowing for up to 18 new parcels. A revised shadow plat showing what those partitions may look like is attached and replaces and supersedes the Applicant's prior submission.

Each new residential parcel created through partition would abut approximately 25 ft of developed 50 ft road right of way with the right to utilize all 50 ft of the proposed access and utility easement connecting to the existing paved right of way. In all cases, the Applicant would grant and reserve a 50 ft wide easement allowing for the future build out and installation of streets and utilities.

Under this proposal, the Applicant would make use of existing infrastructure and facilities while allowing a modest number of new homes. Should either of those two new residential parcels created by partition be further divided, the applicant proposes a condition of approval that appropriate infrastructure would be required at that time.

Applicant is in agreement with the recommendations # 1 and # 2 in City Engineer's memorandum of December 9, 2020. Although not required to demonstrate compliance with applicable approval criteria, to address the City' Engineers concern, Applicant suggests that recommendation # 3 be modified to allow for the further serial partition and development of the remainder parcel 3 as described in this letter and Applicant's prior submissions. To that end, Applicant proposes a condition of approval as follows:

"Condition of Approval: Additional land division of parcel 1 or parcel 2 for further residential development will require the construction of sidewalk, road and utility corridors, as necessary, in the locations shown on the approved partition map(s) to service those additional parcels or lots. The remainder parcel 3 may be further partitioned, in one or more applications, with each partition application creating two new residential parcels and one remainder parcel. With respect to each such partition application, provided that the new residential parcels abut the terminus of an existing paved street allowing connection to existing sewer, water and power, the new residential parcels may take access to and connect with the existing street and utilities and no additional infrastructure shall be required to be constructed in connection with the development of those residential parcels. Additional land division of either of the residential parcels for further residential

development will require the construction of sidewalk, road and utility corridors, as necessary, in the locations shown on the approved partition map(s) to service those additional parcels or lots. This process may be repeated for each of the nine (9) street terminuses abutting the currently vacant Lot 36. All access and utilities shall be located within the dedicated access and utility easement except for where such access and utilities divert from said easement to service the individual residences. Nothing in this condition requires that any residential parcel or remaining parcel be further partitioned or subdivided or prohibits the subdivision of any remaining parcel."

Sincerely,

NOTEBOOM LAW, LLC

/s/ Aaron Noteboom

Aaron J. Noteboom

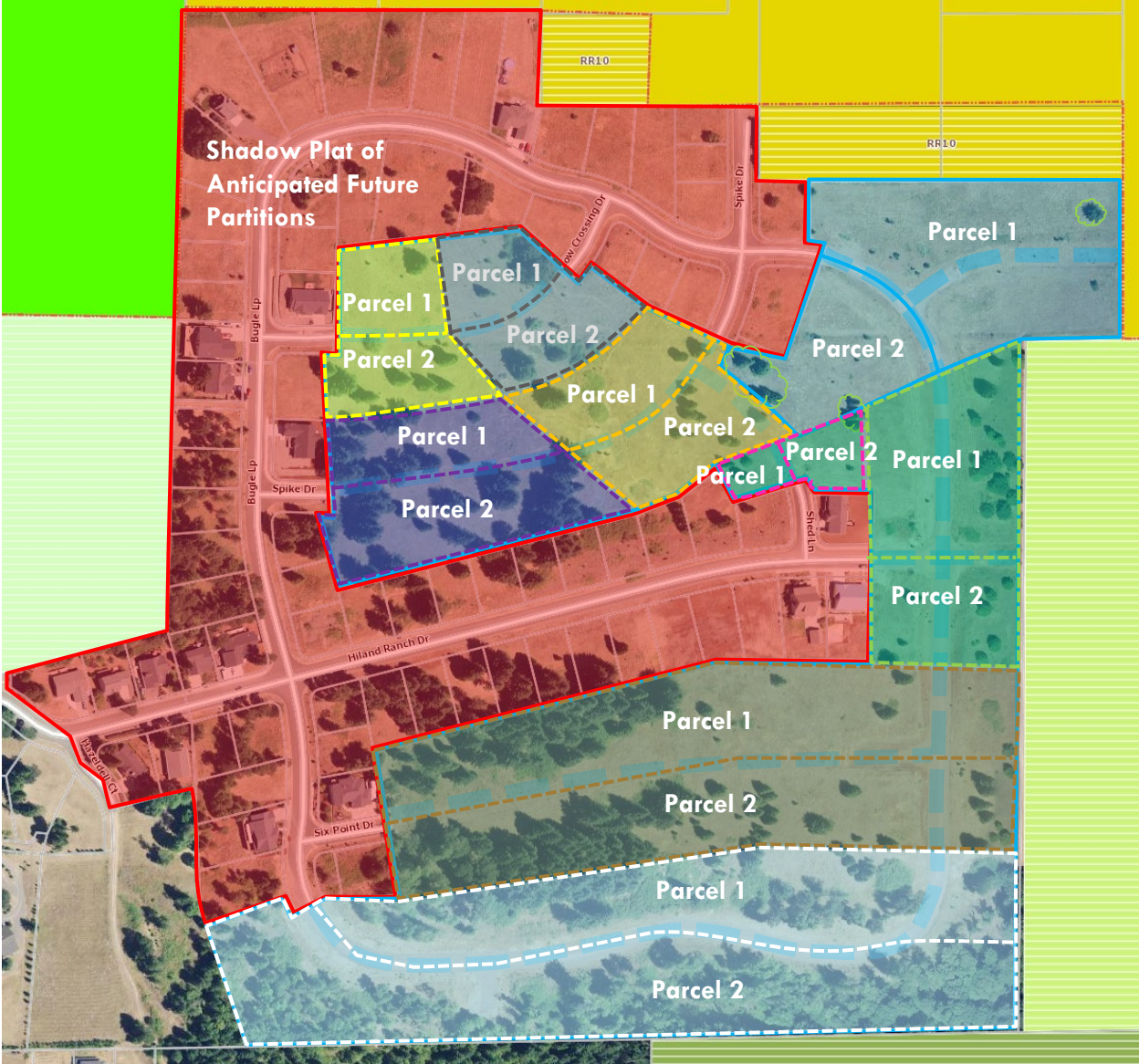

Shadow Plat Map showing Serial Partitions Revised 12.30.2020

ATTACHMENT C

CURRAN-McLEOD, INC. CONSULTING ENGINEERS

6655 S.W. HAMPTON STREET, SUITE 210
PORTLAND, OREGON 97223

December 9, 2020

MEMORANDUM

TO: Henry O. Hearley, Associate Planner, Lane Council of Governments

FROM: Edward Hodges, P.E. *EHO*

CC: Brian Cutchen, City Administrator, City of Oakridge

RE: **CITY OF OAKRIDGE**
PROPOSED ELK MEADOWS PARTITION REVISED SUBMISSION

Henry:

This memorandum is in response to your email dated, December 2, 2020, concerning the above proposed partition.

CURRAN-McLEOD, INC. has reviewed the correspondence dated November 12, 2020, from Aaron J. Noteboom, Esquire, concerning the revised application to partition Lot 36, of the Elk Meadows subdivision. From Mr. Noteboom's submission, we understand that the existing Lot 36 will be partitioned into three Parcels, Parcel 1 with approximately 3.6 acres, Parcel 2, approximately 2 acres and Parcel 3, approximately 33.6 acres. This proposed partition scenario is shown on the figure titled, "Tentative Partition For Highland Ranch Properties, Inc." by Nickell Land Survey and Planning, LLC and other figures contained in the submittal.

The revised application also states that the Applicant "would reserve across the newly partitioned parcels easements for utilities" and "access that mirror the original planned location for those facilities". It also states that "existing CC&R" would remain in place to ensure a continuity of residential development.

It is our understanding from the submission, that a single dwelling will be built on each of Parcels 1 and 2, at some time in the future. Utilities and access to these two structures will originate at the existing eastern termination of "Bugle Loop". Concerning additional future development of proposed Parcel 3, the areas located north of Highland Road and bounded by Bugle Loop, and south of Highland Ranch Road, would be subdivided into smaller parcels, similar to the Parcel 1 and 2 currently proposed. This partitioning will take place at a yet to be determined time in the future.

The applicant is proposing to not perform any improvements to roads and utilities for the two residences to be built in Parcels 1 and 2. However they state that future development of Parcels 1 and 2 would be "subject to City requirements for improving/extending services".

Mr. Henry O. Hearley

December 9, 2020

Page 2

CURRAN-McLEOD, INC. has the following recommendations to the City, based upon our review of the proposed partition and revised submission:

- 1) The locations of all proposed road alignments and utility corridors, which would appear to be the same as the originally platted Elk Meadows Sub-Division, shall be shown on the Partition maps submitted for approval.
- 2) The development of a single residence on each of the Parcels 1 and 2, as proposed, does not appear to require additional construction of utilities or roadway, other than that required to serve the residences. All such access and utilities shall be located within dedicated easements.
- 3) Additional development of Parcels 1, 2 and 3, beyond that discussed in 2), will require the construction of sidewalk, road and utility corridors, as necessary, in the locations shown on the approved partition map(s) from 1).

Don't hesitate to call if you have questions and or concerns about this matter.

Thanks,

Ed

CURRAN-McLEOD, INC.
CONSULTING ENGINEERS

6655 S.W. HAMPTON STREET, SUITE 210
PORTLAND, OREGON 97223

January 22, 2021

MEMORANDUM

TO: Henry O. Hearley, Associate Planner, Lane Council of Governments

FROM: Edward Hodges, P.E. *EPA*

CC: Bryan Cutchen, City Administrator, City of Oakridge

**RE: CITY OF OAKRIDGE
PROPOSED ELK MEADOWS PARTITION**

Henry:

This memorandum follows up on a conversation between the City of Oakridge and Steve Ness occurring January 14, 2021, and also in response to correspondence dated January 8, 2021, from Aaron J. Noteboom, Esquire concerning this matter.

We recommend that the City accept the "**Condition of Approval**" set forth by Mr. Noteboom, in paragraph 5, pp. 2 and 3 of the letter, with the following modification. Any and all Parcels created, including the currently proposed Parcel 1 and 2, which abut utility right of way where water main is shown on the original platted plans, shall have that section of water main bordering the Parcel constructed as a condition of partitioning. The water mains shall be minimum six-inch diameter, of C900 PVC construction, with fire hydrants and valving installed every 500 feet, and will conform to City Public Works Standards and all construction requirements shown in the original platted plans.

The intent of this requirement is that sectional extension of the existing municipal water distribution system in Elk Meadows, as proposed in the originally platted subdivision, shall occur from current and future partitioning. This requirement, and our stated acceptance of the partitioning proposal, does not exempt parcel owners from the additional infrastructure construction requirements described in the "**Condition of Approval**", when parcel sub-division for "further residential development" occurs.

Don't hesitate to call if you have questions and or concerns about this matter.

Thanks,

Ed

ATTACHMENT D

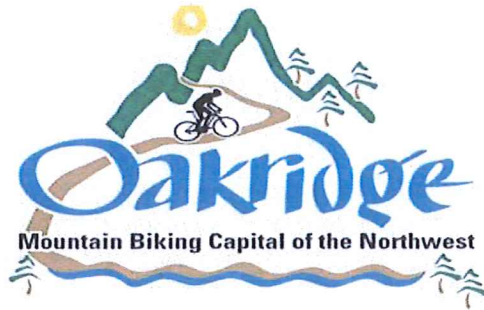

PUBLIC HEARING NOTICE

DEC 28 2020

Mailing Date of this Notice _____

THE CITY OF OAKRIDGE PLANNING COMMISSION WILL HAVE A PUBLIC HEARING

THIS REQUEST IS FOR A TENTATIVE PARTITION FOR HILAND RANCH PROPERTIES LOCATED AT ASSESSOR'S MAP AND TAX LOT 21-35-16-00 TL 1300. The subject property does not contain an address, but an easily understood geographical reference would be the large open, vacant fields located near Hiland Ranch Drive and Bugle Loop Drive (see attached reference map).

The proposed partition would partition Lot 36 into two smaller lots for eventual homesite development.

**The applicable criteria for this proposal are:
Article 4 – Low Density Residential District (R-1)
Chapter 151 of Subdivision: Land Partitions & Improvements in Partitions & Design Standards**

Through staff's review of the proposal, it's possible staff may identify other sections of the Code that are relevant to the proposal. In that case, staff will discuss and appropriately address them in the staff report and findings.

**TUESDAY
JANUARY 26, 2021 AT 7:00 P.M.
Remotely via Zoom or in person at WAC 47674 School Street Rm #8**

TESTIMONY MAY BE PRESENTED AT THE HEARING OR BY SUBMITTING A WRITTEN STATEMENT TO THE CITY RECORDER AT OAKRIDGE CITY HALL BEFORE 5:00 P.M. JANUARY 26, 2021, OR AT THE HEARING. SUBMIT WRITTEN TESTIMONY TO JACKIE SIMS AT CITY HALL, PO BOX 1410, OAKRIDGE, OR 97463.

FAILURE TO RAISE AN ISSUE AT THIS HEARING, IN PERSON OR BY LETTER, OR FAILURE TO PROVIDE SUFFICIENT SPECIFICITY TO AFFORD THE DECISION-MAKER AN OPPORTUNITY TO RESPOND TO THE ISSUE PRECLUDES APPEAL TO THE STATE OF OREGON LAND USE BOARD OF APPEALS BASED ON THAT ISSUE. FOR FURTHER INFORMATION ABOUT THIS NOTICE, PLEASE CONTACT JACKIE SIMS, (541) 782-2258, jackiesims@ci.oakridge.or.us

A copy of the application, all documents, and evidence relied upon by the applicant and applicable criteria are available for inspection at no cost and copies can be provided at a reasonable cost or free if emailed electronically.

The staff report will be made available for the public at least seven days before the scheduled public hearing.

Due to the COVID-19 Pandemic, all persons are encouraged to attend, participate and provide testimony remotely via Zoom, however, the City will still be providing a physical location for persons to attend the hearing in person. All persons attending in person will be required to adhere to the current COVID-19 guidelines. **For those wanting to participate remotely, please email or call Jackie Sims to receive the meeting link.**

DEC 28 2020

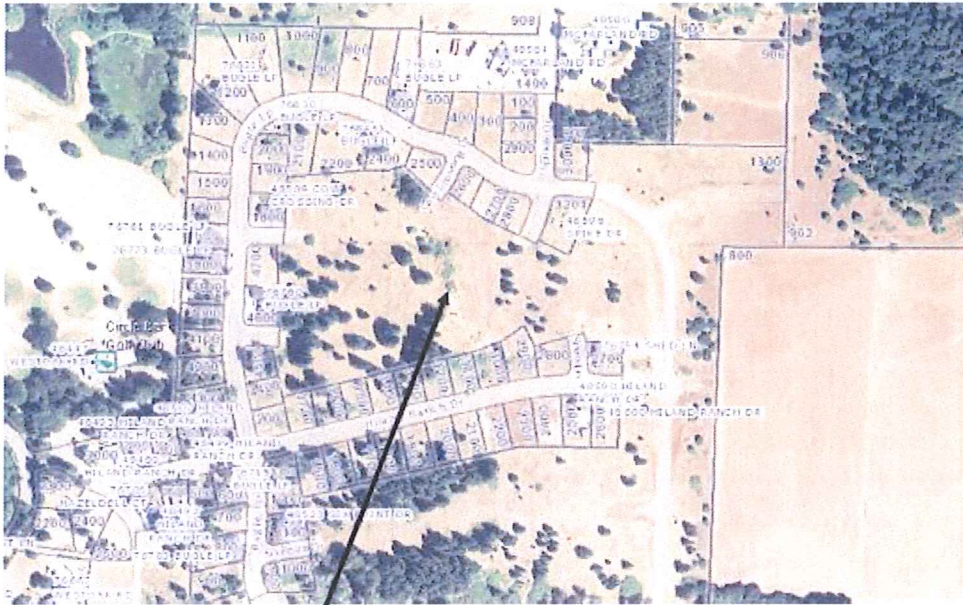

Subject Property (Lot 36)

The City of Oakridge is an equal opportunity, affirmative action institution committed to cultural diversity and compliance with the Americans with Disabilities Act. For the hearing impaired the City's TDD number is (541) 782-4232.

AFFIDAVIT OF MAILING

DEC 28 2020

LANE COUNCIL OF GOVERNMENTS
859 Willamette Street. Suite 500
Eugen, OR 97401

I, Henry Hearley, contracted planner, depose and state that I mailed, by regular first-class mail, on DECEMBER 28, 2020, a notice of a public hearing for a proposed PARTITION at Map and Tax Lot 21-35-16-00 TL 1300, known as the HILAND RANCH PARTITION in the City of OAKRIDGE to the addresses contained herein.



Signature



Print Name

ATTACHMENT E

FINAL ORDER AND DECISION OF THE CITY OF OAKRIDGE PLANNING COMMISSION ATTACHMENT E

HILAND RANCH PARTITION

A. The Oakridge Planning Commission finds the following:

1. The Oakridge Planning Commission has reviewed all materials relevant to the Hiland Ranch Partition that has been submitted by the applicant and staff regarding this matter for Assessors Map 21-35-16-00 Tax Lot 1300, including the criteria, findings and conclusions within the staff report.
2. On January 26, 2021, the Oakridge Planning Commission reviewed the application and record after giving the required notice as per the Oakridge Development Code and held a public hearing that was open to the public.
3. At the January 26, 2021 hearing, the Oakridge Planning Commission made a motion to **approve** the application subject to the conclusions, findings and conditions as contained in the staff report.
4. This approval is subject to a 10-day appeal period. The appeal must be submitted within 10-days of Planning Commission rendering its decision. Notice of decision will be mailed out to the applicant and any parties of record.

Signed this _____ day of January 2021.

Mr. Kevin Gobelman, Planning Commission Chair

Detailed Property Report

ATTACHMENT F

Site Address N/A
Map & Taxlot# 21-35-10-00-01300
SIC N/A
Tax Account# 1800661

Property Owner 1
 Hiland Ranch Properties Inc
 2880 Arrowhead St
 Eugene, OR 97404-3815
 Tax account acreage 39.27
 Mapped taxlot acreage† 39.28

† Mapped Taxlot Acreage is the estimated size of a taxlot as derived from the county GIS taxlot layer, and is not to be used for legal purposes.

Map & Taxlot # 21-35-10-00-01300



Business Information

RLID does not contain any business data for this address

Improvements

No assessor photos, assessor sketches or building characteristic information is available for this tax account.

Site Address Information

No site address associated with this tax account number

General Taxlot Characteristics

▣ **Geographic Coordinates**
 X 4406916 Y 766685 (State Plane X,Y)
Latitude 43.7539 **Longitude** -122.4469

▣ **Zoning**
Zoning Jurisdiction Oakridge
 Oakridge
Parent Zone R1 Low-Density Residential

▣ **Land Use**
General Land Use

Code	Description
data not available	data not available

Detailed Land Use

Code	Description
data not available	data not available

Taxlot Characteristics

Incorporated City Limits	Oakridge
Urban Growth Boundary	Oakridge
Year Annexed	2006
Annexation #	06-45
Approximate Taxlot Acreage	39.28
Approx Taxlot Sq Footage	1,711,037
Plan Designation	Urban Residential
Eugene Neighborhood	N/A
Metro Area Nodal Dev Area	No
Septic	data not available
Well	data not available
Landscaping Quality	data not available
Historic Property Name	N/A
City Historic Landmark?	No
National Historical Register?	No

Service Providers

Fire Protection Provider Oakridge FD
 Ambulance Provider Oakridge Fire & EMS
 Ambulance District SE
 Ambulance Service Area South/East
 LTD Service Area? No
 LTD Ride Source? No

Environmental Data

FEMA Flood Hazard Zone

Code Description

- X Areas determined to be outside of 500-year flood.
- D Areas in which flood hazards are undetermined (not mapped).

FIRM Map Number 41039C2225F
 Community Number 410126
 Post-FIRM Date 06/03/1986
 Panel Printed? No

Soils

Soil Map Unit#	Soil Type Description	% of Taxlot	Ag Class	Hydric %
89D	Nekia silty clay loam, 12 to 20 percent slopes	62%	3	0
89E	Nekia silty clay loam, 20 to 30 percent slopes	38%	4	0

Schools

	Code	Name
School District	76	Oakridge
Elementary School	600	Oakridge
Middle School	601	Oakridge
High School	602	Oakridge

Political Districts

Election Precinct	4800	State Representative District 7	Emerald PUD Board Zone	N/A
City Council Ward	N/A	State Representative	Cedric Hayden	Heceta PUD Board Zone
City Councilor	N/A	State Senate District	4	Central Lincoln PUD Board Zone
County Commissioner District	5 (East Lane)	State Senator	Floyd Prozanski	Soil Water Cons. Dist/Zone
County Commissioner	Heather Buch			Upper Willamette / 4
EWEB Commissioner	N/A			
LCC Board Zone	4			

Census Information

The information provided below is only a small sampling of the information available from the US Census Bureau. The links at the end of each section below will take you to source tables at American Fact Finder, with additional details. Those links will take you to the most current estimates, but estimates for several previous years will also be available.

To view more Census detail about this tract, visit [Census Reporter](#).

Demographic Characteristics	Tract 1500		Oakridge		Lane County		Oregon	
	Estimate	Margin of Error	Estimate	Margin of Error	Estimate	Margin of Error	Estimate	Margin of Error
Total Population	4,480	+/-361	3,228	+/-18	363,471	*****	4,025,127	*****
Percent age 5 and Under	2.4%	+/-1.8	2.4%	+/-2.3	5.0%	*****	5.8%	+/-0.1
Percent Age 18 and Over	85.6%	+/-4.0	89.5%	+/-4.8	81.0%	*****	78.5%	+/-0.1
Percent Age 65 and Over	26.9%	+/-4.5	26.5%	+/-7.1	17.7%	+/-0.1	16.3%	+/-0.1
Median Age	52.6	+/-4.4	50.5	+/-9.9	39.4	+/-0.2	39.2	+/-0.2

For a complete breakdown of population by age, gender, race, ethnicity and more, visit [American Fact Finder](#).

Housing Characteristics	Tract 1500		Oakridge		Lane County		Oregon	
	Estimate	Margin of Error	Estimate	Margin of Error	Estimate	Margin of Error	Estimate	Margin of Error
Occupied Housing Units	1,989	+/-281	1,488	+/-201	148,752	+/-787	1,571,631	+/-4,213
Vacant Housing Units	405	+/-174	342	+/-165	11,688	+/-774	161,410	+/-3,975
Percent Owner Occupied Housing Units	68.3%	+/-8.5	62.1%	+/-10.7	58.8%	+/-0.7	61.7%	+/-0.3
Percent Renter Occupied Housing Units	31.7%	+/-8.5	37.9%	+/-10.7	41.2%	+/-0.7	38.3%	+/-0.3
Homeowner Vacancy Rate	8.7%	+/-6.7	11.7%	+/-9.4	1.3%	+/-0.3	1.5%	+/-0.1
Rental Vacancy Rate	13.8%	+/-12.9	14.8%	+/-14.2	3.9%	+/-0.7	3.7%	+/-0.2
Median House Value (dollars)	122,000	+/-22,122	109,400	+/-24,252	232,800	+/-2,334	265,700	+/-1,159
Median Monthly Mortgage (dollars)	1,053	+/-133	919	+/-279	1,454	+/-16	1,594	+/-6
Median Monthly Rent (dollars)	817	+/-72	807	+/-73	921	+/-11	988	+/-4

For a complete breakdown of housing by tenure, number of bedrooms, year built and more, visit [American Fact Finder](#).

Economic Characteristics	Tract 1500		Oakridge		Lane County		Oregon	
	Estimate	Margin of Error	Estimate	Margin of Error	Estimate	Margin of Error	Estimate	Margin of Error
Median Household Income (dollars)	(X)	(X)	(X)	(X)	(X)	(X)	(X)	(X)
Unemployment Rate	(X)	(X)	(X)	(X)	(X)	(X)	(X)	(X)
Poverty Rate	29.1%	+/-9.3	31.7%	+/-10.9	18.8%	+/-0.7	14.9%	+/-0.3

For a complete breakdown of incomes, poverty, employment, commute patterns and more, visit [American Fact Finder](#).

Social Characteristics	Tract 1500		Oakridge		Lane County		Oregon	
	Estimate	Margin of Error	Estimate	Margin of Error	Estimate	Margin of Error	Estimate	Margin of Error
Percent Bachelor Degree or Higher	17.3%	+/-5.9	13.6%	+/-7.4	29.6%	+/-0.6	32.3%	+/-0.2
Percent High School Graduate or Higher	81.3%	+/-5.4	79.7%	+/-6.4	91.5%	+/-0.5	90.2%	+/-0.2

For a complete breakdown of educational attainment, school enrollment, marital status, ancestry and more, visit [American Fact Finder](#).

Source: U.S. Census Bureau, 2012-2016 American Community Survey 5-Year Estimates

Explanation of Symbols:

An '*****' entry in the margin of error column indicates that the estimate is controlled, and a margin of error is not provided.

Liens

None. RLID displays liens issued by Cottage Grove, Florence, the City of Springfield and Springfield Utility Board. Additional liens can be found in Deeds and Records.

Building Permits

RLID does not contain any building permit data for this jurisdiction

Land Use Applications

RLID does not contain any landuse application data for this jurisdiction

Petitions

RLID does not contain any petition data for this jurisdiction

Tax Statements & Tax Receipts

Account#: 1800661
View tax statement(s) for: [2020](#) [2019](#)

Tax Receipts

Receipt Date	Amount Received	Tax	Discount	Interest	Applied Amount
11/04/2020	\$8,223.41	\$8,223.41	\$254.33	\$0.00	\$8,477.74
11/15/2019	\$9,308.83	\$9,308.83	\$287.90	\$0.00	\$9,596.73
11/07/2018	\$9,071.63	\$9,071.63	\$280.57	\$0.00	\$9,352.20

Data source: Lane County Assessment and Taxation

Owner/Taxpayer

Owners

Owner	Address	City/State/Zip
Hiland Ranch Properties Inc	2880 Arrowhead St	Eugene, OR 97404-3815

Taxpayer

Party Name	Address	City/State/Zip
Hiland Ranch Properties Inc	2880 Arrowhead St	Eugene, OR 97404-3815

Data source: Lane County Assessment and Taxation

Account Status

Status Active Account Current Tax Year

Account Status	none
Remarks	none
Special Assessment Program	N/A

Data source: Lane County Assessment and Taxation

General Tax Account Information

Tax Account Acreage	39.27
Fire Acres	39.27
Property Class	190 - Residential, potential development, vacant
Statistical Class	N/A
Neighborhood	761300 - Oakridge Urban C Grade
Category	Land and Improvements

Data source: Lane County Assessment and Taxation

Township-Range-Section / Subdivision Data

Subdivision Type	Subdivision Plat	Subdivision Name	Elk Meadows Phase Ii	Subdivision Number	N/A
Phase	N/A	Lot/Tract/Unit #	Parcel 36 TL 01300	Recording Number	2007-068321

Data source: Lane County Assessment and Taxation

Property Values & Taxes

The values shown are the values certified in October unless a value change has been processed on the property. Value changes typically occur as a result of appeals, clerical errors and omitted property. The tax shown is the amount certified in October. This is the full amount of tax for the year indicated and does not include any discounts offered, payments made, interest owing or previous years owing. It also does not reflect any value changes.

Year	Real Market Value (RMV)			Total Assessed Value	Tax
	Land	Improvement	Total		
2020	\$541,238	\$0	\$541,238	\$541,238	\$8,477.74
2019	\$618,548	\$0	\$618,548	\$618,548	\$9,596.73
2018	\$607,365	\$0	\$607,365	\$607,365	\$9,352.20
2017	\$596,183	\$0	\$596,183	\$596,183	\$9,049.85
2016	\$607,365	\$0	\$607,365	\$602,550	\$9,317.00
2015	\$585,000	\$0	\$585,000	\$585,000	\$9,082.73
2014	\$584,403	\$0	\$584,403	\$583,966	\$9,374.23
2013	\$566,957	\$0	\$566,957	\$566,957	\$9,252.57
2012	\$584,402	\$0	\$584,402	\$556,400	\$8,940.43
2011	\$584,402	\$0	\$584,402	\$540,194	\$8,496.10
2010	\$601,846	\$0	\$601,846	\$524,460	\$8,262.66
2009	\$780,000	\$0	\$780,000	\$509,184	\$8,555.23
2008	\$967,371	\$0	\$967,371	\$561,656	\$9,615.57
2007	\$0	\$0	\$0	\$0	\$0.00

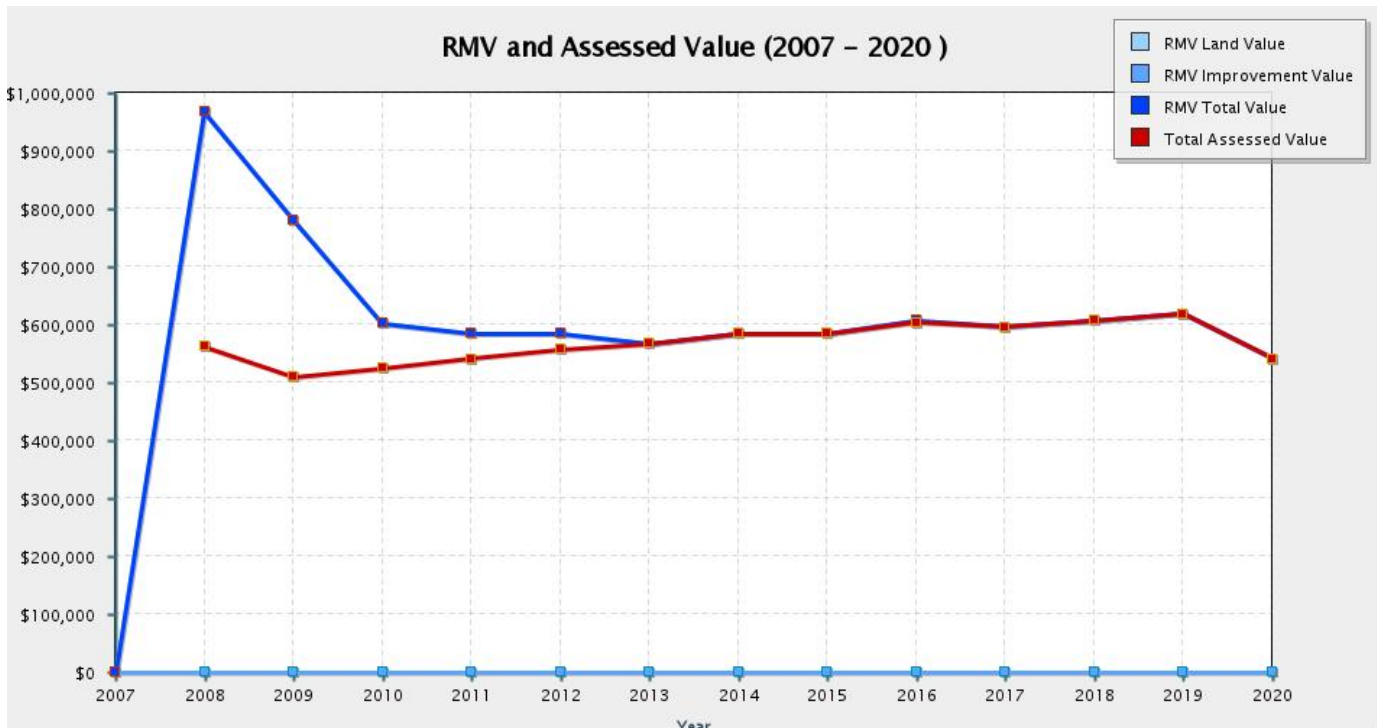

Current Year Assessed Value \$541,238
 Less Exemption Amount * N/A
 Taxable Value **\$541,238**

* Frozen Assessed Value

Data source: Lane County Assessment and Taxation

Tax Code Area & Taxing Districts

Tax Code Area (Levy Code) for current tax year 07600
 Taxing Districts for TCA 07600
 City of Oakridge
 Lane Community College
 Lane County
 Lane Education Service District
 Oakridge School District 76

****NOTE** Lane County Assessment and Taxation Tax Code Area & Taxing Districts reflect the current certified year. The **Billing Rate Document** may still reference the prior year's rates and details until we receive the current report from Lane County.

Data source: Lane County Assessment and Taxation

Sales & Ownership Changes

Sale Date	Sale Price	Doc #	Image	Analysis Code	Multiple Accts?	Grantor(s)	Grantee(s)
12/01/2015	\$0	2015-58663		8	Yes	Casey & Casey LLC	Hiland Ranch Properties Inc

Data source: Lane County Assessment and Taxation